

### SYSTEM INFORMATION

The Dual-Air Quiet (DQ) Systems are designed to provide refrigerated air to 55–65 °F. DQ evaporators return air at the bottom and supply two-way air discharge 10–12 feet in both directions at a medium velocity airflow. This promotes fantastic circulation in long and narrow display cases.

DQ evaporators are available in standard capacities from 1,800 to 4,600 BTU per hour and are used with an R134a refrigerant.

### FEATURES

- Air defrosting coil requires no additional heater
- Low-noise fan blades
- High performance staggered coils with copper tubing mechanically expanded into aluminum fins
- Insulated rust-proof aluminum housing
- Thermally protected permanently lubricated motor
- Automatic expansion valve (standard) ensures constant coil temperature to promote "Humidity Balance"
- Pump-down solenoid valve (standard) protects compressor in the event of leaks.

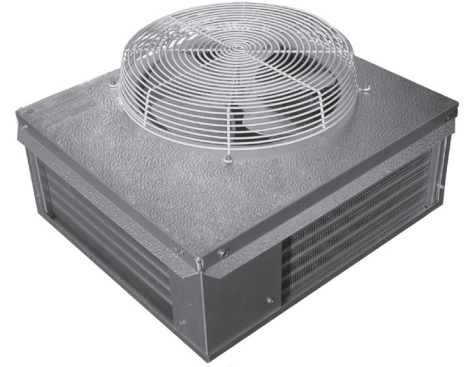

### BEST SELLERS

| Dual-Air Quiet                        | DQ2600 | DQ3600 | DQ4600 | DQ6600 TE | DQ8600 TE |
|---------------------------------------|--------|--------|--------|-----------|-----------|
| Max Cubic Feet                        | 300    | 650    | 1,000  | 1,500     | 2,000     |
| BTUH                                  | 2600   | 3600   | 4600   | 6600      | 8600      |
| Fan Coil                              | DQ207  | DQ275  | DQ275  | DQ275 x2  | DQ275 x2  |
| Length                                | 23"    | 23"    | 23"    | 23"       | 23"       |
| Width                                 | 17.5"  | 17.5"  | 17.5"  | 17.5"     | 17.5"     |
| Height                                | 7.5"   | 9.5"   | 9.5"   | 9.5"      | 9.5"      |
| Weight                                | 20 lbs | 35 lbs | 25 lbs | 35 lbs    | 35 lbs    |
| Volts                                 | 115 V  | 115 V  | 115 V  | 115 V     | 115 V     |
| Amps                                  | 0.06 A | 0.06 A | 0.06 A | 0.06 A    | 0.06 A    |
| Condensing Unit                       | CU26   | CU36   | CU46   | CU66      | CU86      |
| Length                                | 17"    | 17"    | 17"    | 20.6"     | 17.5"     |
| Width                                 | 12"    | 12"    | 13.46" | 13.9"     | 14.3"     |
| Height                                | 9.4"   | 9.4"   | 12.48" | 13.2"     | 12.0"     |
| Weight                                | 41 lbs | 42 lbs | 55 lbs | 83 lbs    | 79 lbs    |
| Volts                                 | 115 V  | 115 V  | 115 V  | 115 V     | 115 V     |
| Amps MFS                              | 15 A   | 15 A   | 20 A   | 30 A      | 30 A      |
| System Line Set                       |        |        |        |           |           |
| Suction                               | 3/8"   | 3/8"   | 1/2"   | 1/2"      | 5/8"      |
| Liquid                                | 1/4"   | 1/4"   | 1/4"   | 1/4"      | 3/8"      |
| Lines between coils - TE Systems only |        |        |        |           |           |
| Suction                               | -      | -      | -      | 3/8"      | 3/8"      |
| Liquid                                | -      | -      | -      | 1/4"      | 1/4"      |

*Due to continuing engineering improvements, specifications are subject to change without notice.*

# DQ SERIES

## DQ Fan Coil Specifications

- Expansion valve and liquid line solenoid valve standard
- Suction line accumulators recommended

| MODEL  | WIDTH | A     | B     | CFM | FAN DIA | MOTOR | AMPS<br>115 V | LIQUID | SUCTION | DRAIN | APPROX<br>SHIP WT. |
|--------|-------|-------|-------|-----|---------|-------|---------------|--------|---------|-------|--------------------|
| DQ 207 | 17.5" | 7.5"  | 4.75" | 350 | 10"     | 16 W  | 0.06          | 3/8"   | 1/2"    | 3/8"  | 30                 |
| DQ 275 | 17.5" | 9.5"  | 6.75" | 465 | 12"     | 16 W  | 0.06          | 3/8"   | 1/2"    | 3/8"  | 35                 |
| DQ 345 | 17.5" | 10.5" | 7.75" | 580 | 12"     | 16 W  | 0.06          | 3/8"   | 1/2"    | 3/8"  | 40                 |

Due to continuing engineering improvements, specifications are subject to change without notice.

## Mounting Diagrams

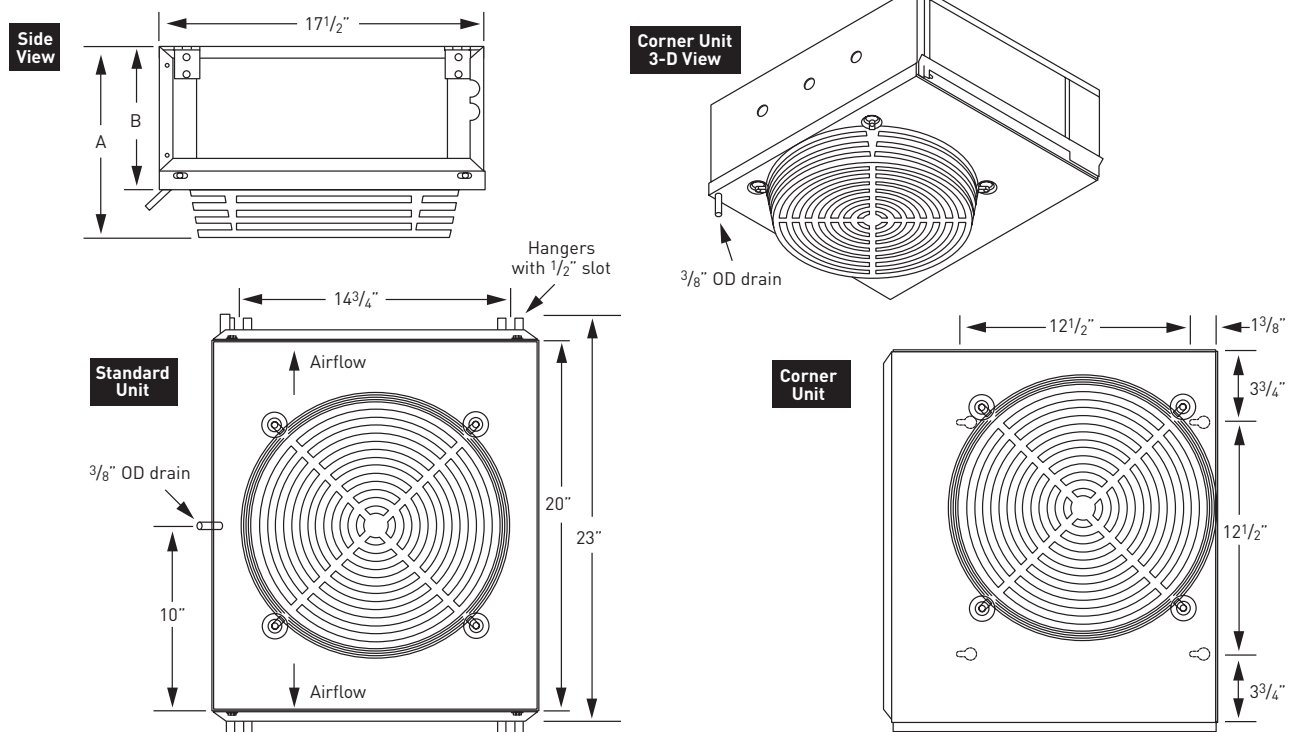

## Single Fan Coil Wiring

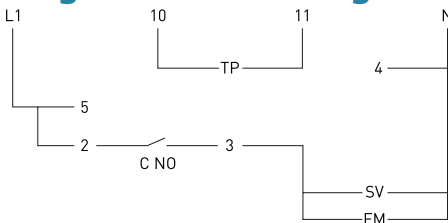

## TE Fan Coil Wiring

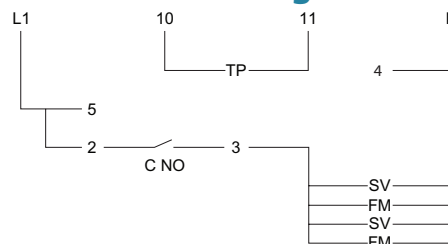

## Field Wiring

- L1** 115 V Line Voltage
- N** Neutral
- SV** Solenoid Valve
- FM** Fan Motor
- TP** Temperature Probe

## Condensing Unit Wiring



## Back of Controller Connections

- 10** Temperature Probe
- 11** Temperature Probe
- 4** Neutral
- 5** 115V Line Voltage
- 2** Jumper from 5
- 3** Switch Leg to Fan Coil
- C NO** Internal normally open contact

## DQ Cooling System Typical Installation

- Keep line sets as short as possible.
- Excessive number of turns will cause refrigerant flow problems. This could cause early compressor failure. Suction line accumulators are recommended. Required if working lower than the normal 55-65° operating range from wine cellar.
- Drain line must always flow downhill to drain or pump
- The system is controlled by a pump down control system. There is no control wiring between thermostat and condensing unit
- The line connections at Fan Coil and Condensing Unit may not be the same as the required line sizes
- Standard line sets should be 50' or less. Extended runs may require larger line sizes and 3oz. oil must be added for every 10' over 35'.

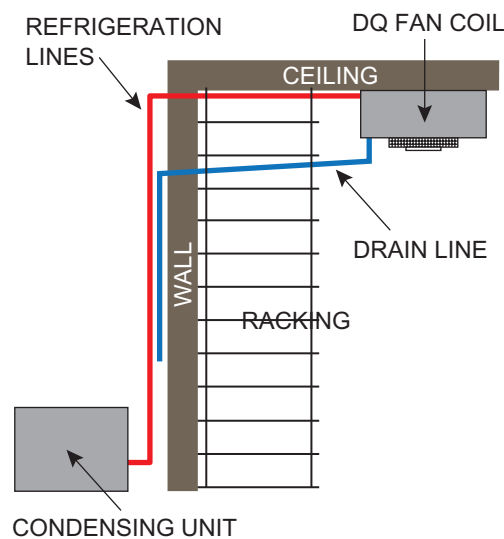
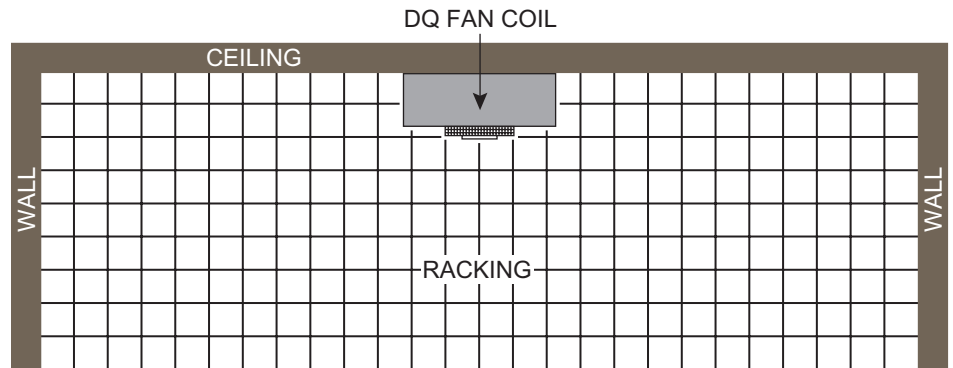

## Ceiling Construction



EXTERIOR  
 VAPOR BARRIER  
 INSULATION –  
 R19 OR BETTER  
 INTERIOR

## Wall Construction



EXTERIOR  
 VAPOR BARRIER  
 INSULATION –  
 R12 OR BETTER  
 INTERIOR

# DQ TE SERIES

## DQ TE Cooling System Typical Installation

- Keep line sets as short as possible.
- Excessive number of turns will cause refrigerant flow problems. This could cause early compressor failure. Suction line accumulators are recommended. Required if working lower than the normal 55-65° operating range from wine cellar.
- Drain line must always flow downhill to drain or pump
- The system is controlled by a pump down control system. There is no control wiring between thermostat and condensing unit
- The line connections at Fan Coil and Condensing Unit may not be the same as the required line sizes
- Standard line sets should be 50' or less. Extended runs may require larger line sizes and 3oz. oil must be added for every 10' over 35'.

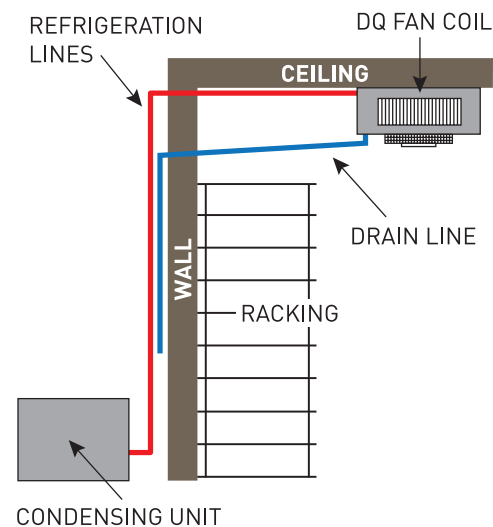
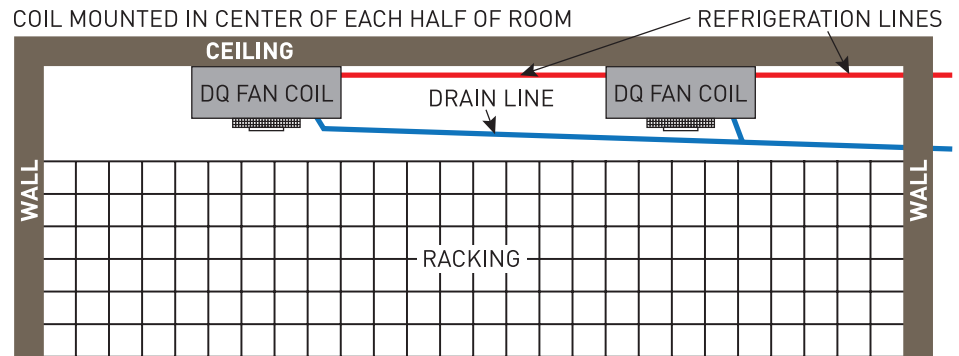

## Ceiling Construction



EXTERIOR  
 VAPOR BARRIER  
 INSULATION –  
 R19 OR BETTER  
 INTERIOR

## Wall Construction



EXTERIOR  
 VAPOR BARRIER  
 INSULATION –  
 R12 OR BETTER  
 INTERIOR