

***Mini Ceiling Mount***  
**OWNER'S MANUAL**

***Whisper*KOOL™**  
*The Coolest Thing In Wine Storage*

MCM 082814

***We manufacture, test and certify 100% of our wine cooling units in the USA. By sourcing the best components and closely controlling our manufacturing processes, we can assure the highest-quality, lowest defect manufacturing rates in the industry.***

Copyright © 2012. WhisperKOOL. All rights reserved.

WhisperKOOL copyrights this manual, the product design, and the design concepts, with all rights reserved. Your rights with regard to the hardware and manual are subject to the restrictions and limitations imposed by the copyright laws of the USA. Under copyright laws, this manual may not be copied, reproduced, translated, transmitted, or reduced to any printed or electronic medium or to any machine-readable form, for any purpose, in whole or in part, without the written consent of WhisperKOOL.

Every effort has been made to ensure that the information in this manual is accurate. WhisperKOOL is not responsible for printing or clerical errors.

WhisperKOOL reserves the right to make corrections or improvements to the information provided and to the related hardware at any time, without notice.

Vinothèque and WhisperKOOL are registered trademarks, and ECE is a trademark of WhisperKOOL. All rights reserved.

Mention of third-party products is for informational purposes only and constitutes neither an endorsement nor a recommendation. WhisperKOOL assumes no liability with regard to the performance or use of these products.

REV 02

MCM 082814

# TABLE OF CONTENTS

<b>Quick Reference Guide</b>	
Unit .....	2
Knockout Location .....	3
Controller Layout & Specifications .....	4
<b>Introduction .....</b>	<b>5</b>
<b>Receiving &amp; Inspecting the System .....</b>	<b>6</b>
<b>Before You Start .....</b>	<b>7</b>
<b>Preparing the Wine Cellar.....</b>	<b>8</b>
<b>Preparing the installation Location.....</b>	<b>11</b>
<b>Installing the Evaporator .....</b>	<b>13</b>
<b>220V Connection for Mini Ceiling Mount Evaporator .....</b>	<b>19</b>
<b>Drain Line.....</b>	<b>20</b>
<b>Liquid Thermostat (Bottle Probe).....</b>	<b>21</b>
<b>Remote Keypad.....</b>	<b>22</b>
<b>Active Humidity Option .....</b>	<b>23</b>
<b>Humidistat Installation .....</b>	<b>24</b>
<b>Mini Ceiling Mount Wiring Diagram .....</b>	<b>26</b>
<b>Mini Ceiling Mount With Humidity Wiring Diagram .....</b>	<b>27</b>
<b>Preparing the Condensing Unit.....</b>	<b>28</b>
<b>Mini Ceiling Mount Condenser Wiring Diagram .....</b>	<b>29</b>
<b>Mini Ceiling Mount Condenser Wiring Diagram .....</b>	<b>30</b>
<b>Preparing the Condensing Unit (Continued).....</b>	<b>31</b>
<b>Line Set Piping Diagrams .....</b>	<b>32</b>
<b>Installing the Condensing Unit .....</b>	<b>33</b>
<b>System Operation.....</b>	<b>35</b>
<b>Controller Functions.....</b>	<b>36</b>
<b>Maintenance Schedule .....</b>	<b>39</b>
<b>Troubleshooting Guide .....</b>	<b>40</b>
<b>Technical Assistance &amp; Accessories .....</b>	<b>42</b>
<b>Installation Terms and Conditions .....</b>	<b>43</b>

# QUICK REFERENCE GUIDE

## Bottom View

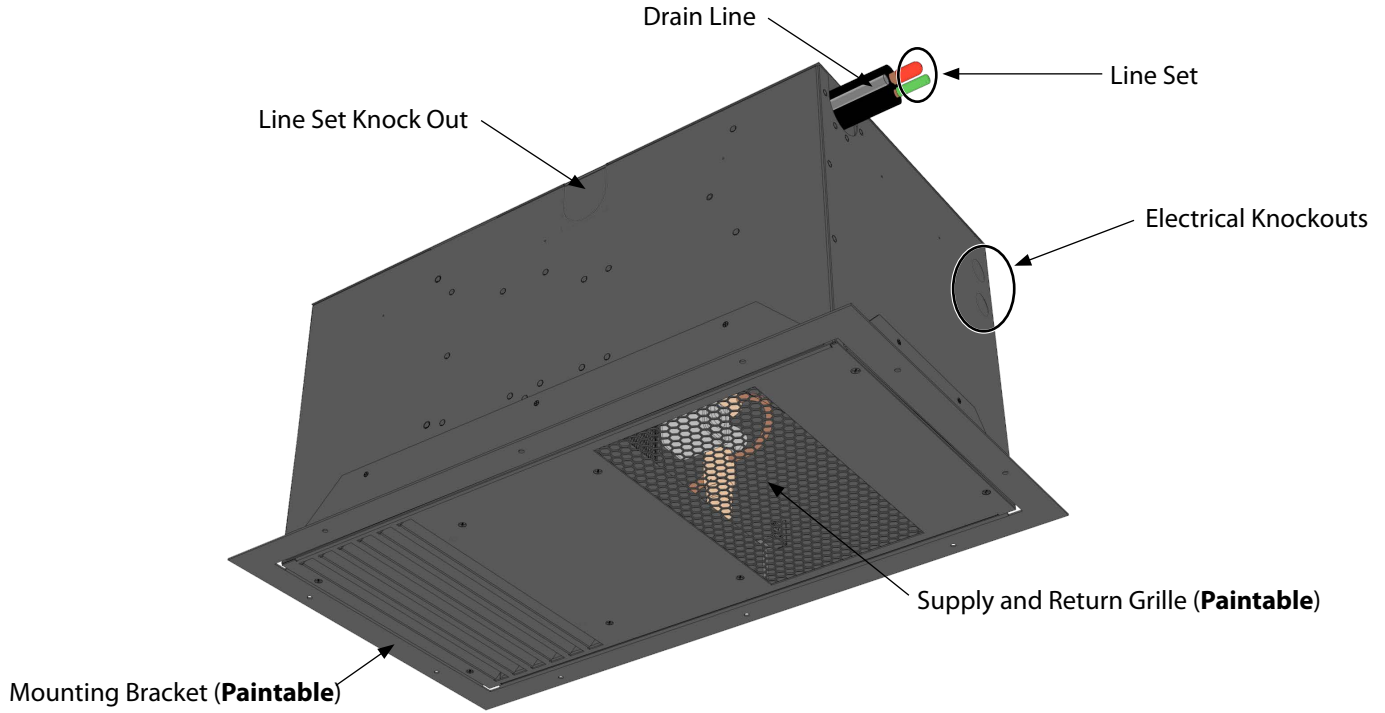

## Top View

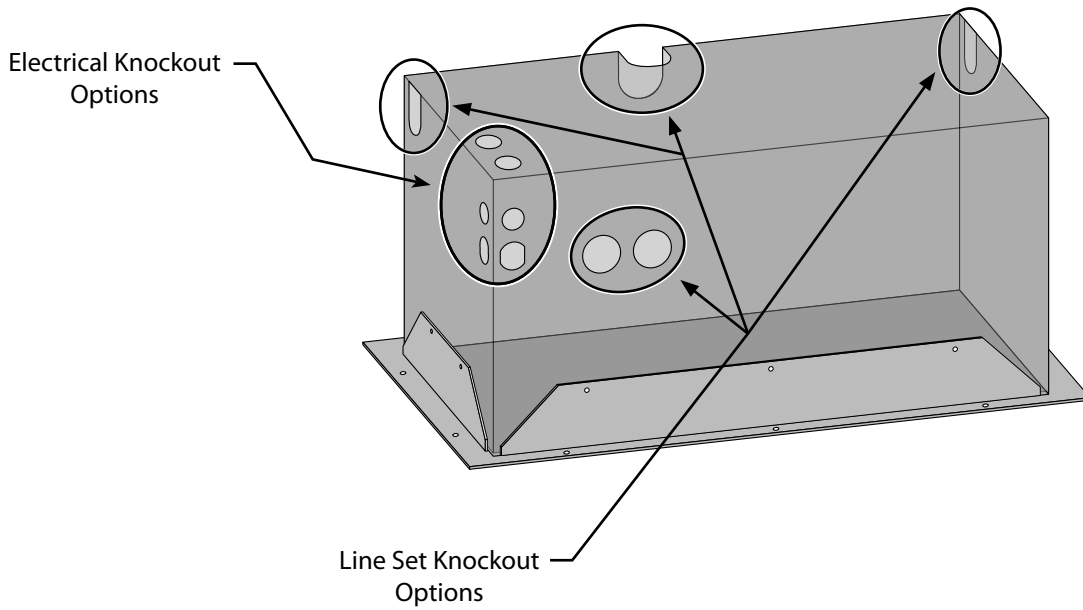

**Note:** The unit comes black. The mounting bracket and front grille are paintable, enabling you to match your desired color.

# KNOCKOUT LOCATIONS

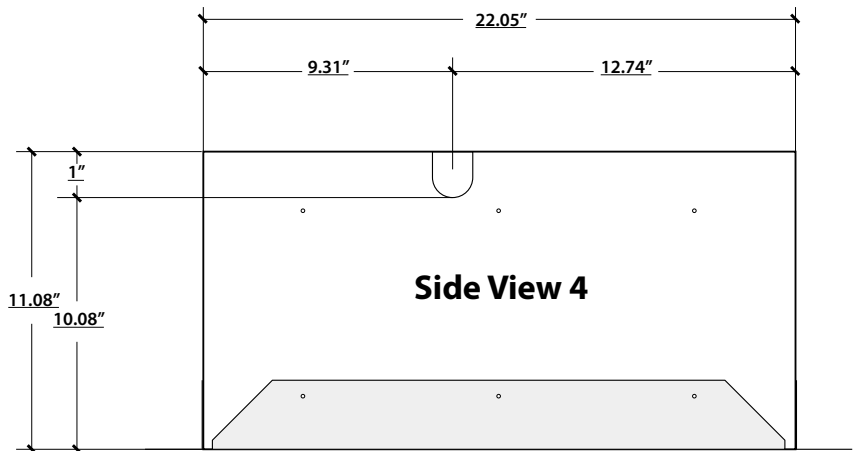
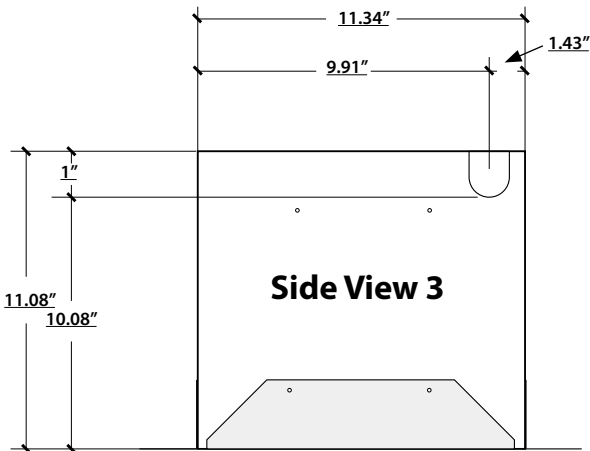
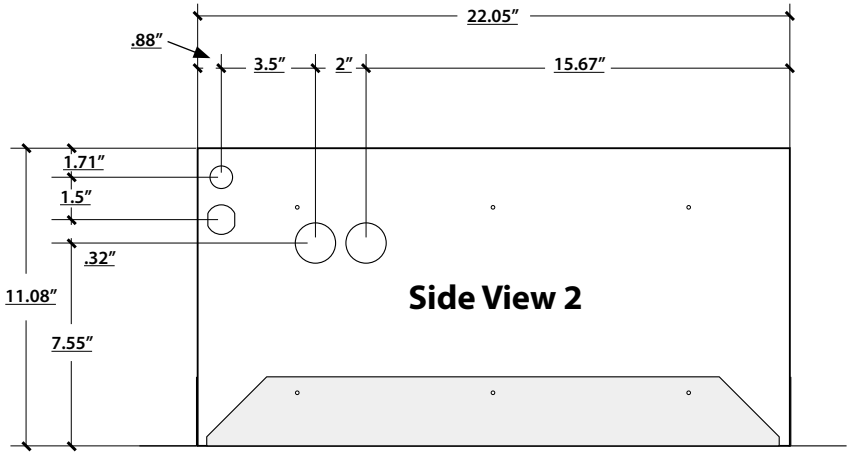
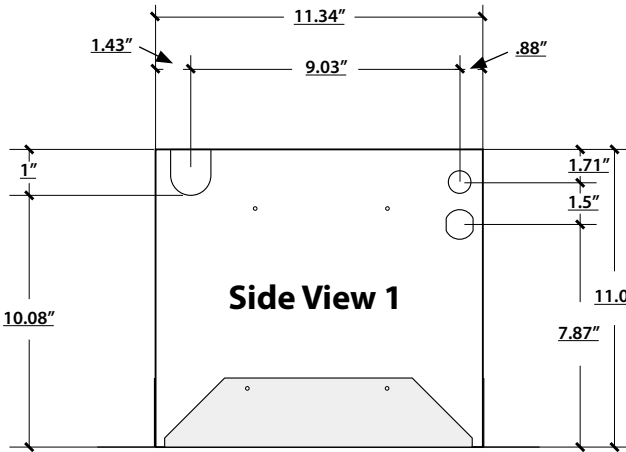
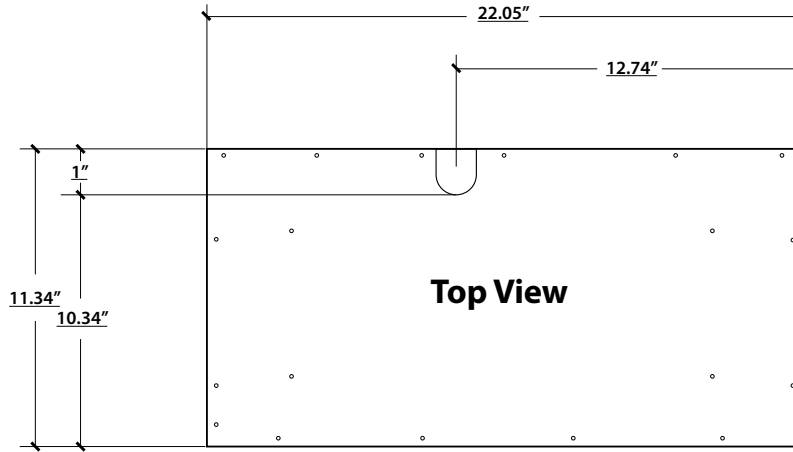

# QUICK REFERENCE GUIDE

## Controller Layout

Refer to page 36 for complete listing of buttons and symbols.

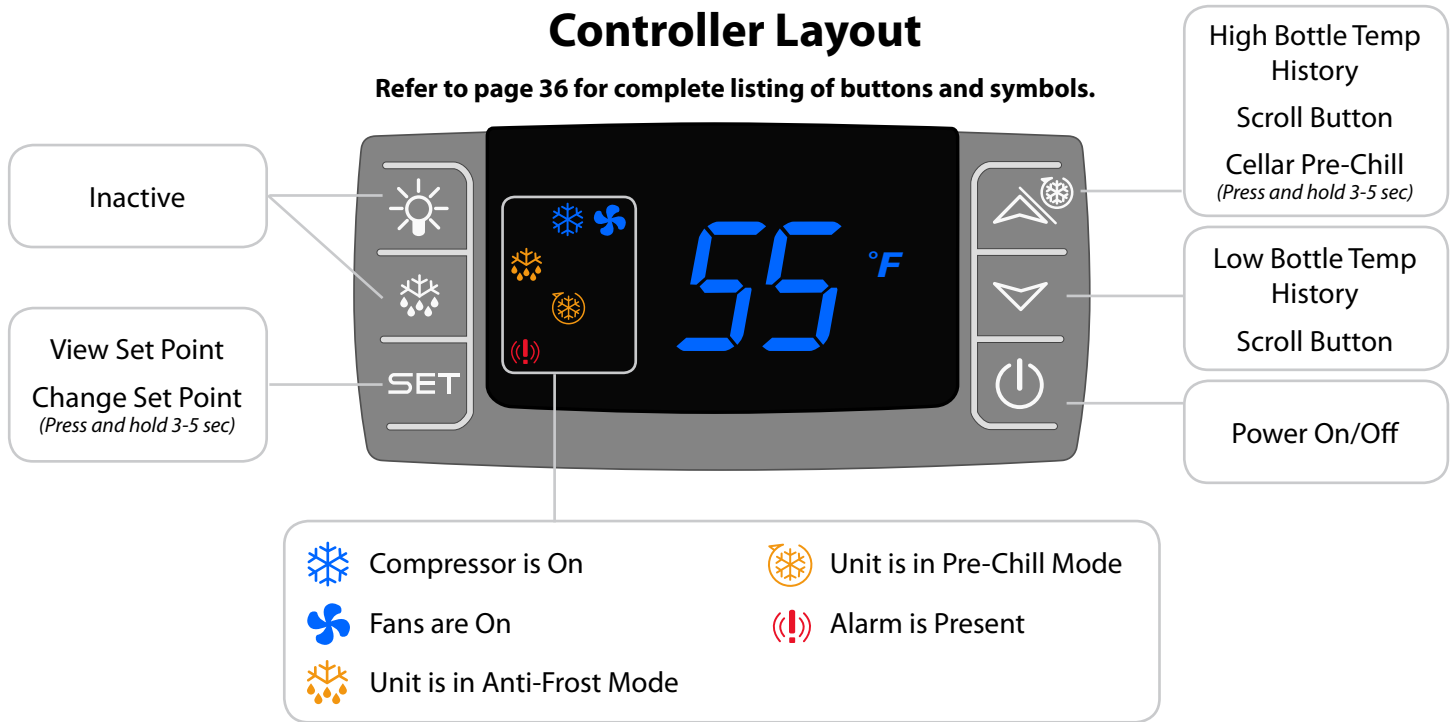

## MINI CEILING MOUNT SPECIFICATIONS

Model	Mini Evaporator (Fan Coil Unit)	Mini Condenser (Air Cooled Condensing Unit)
Cellar Size (cu. ft.)	500	
Dimensions	22.05"L x 11.34"W x 11.08"H	16.0"L x 11.5"W x 10"H
BTU <sub>h</sub> with 90° air entering the Condenser Coil	1540	
CFM	107	190
Refrigerant	R-134a	
Condensing Unit HP	1/5	
Voltage Rating (20 amp dedicated circuit required)	115V	
Weight (lbs)	40.6	40.4
AMPS (Starting/Running)	2/1	11/3.81
dBA	52	65
Line Set (od.)	Suction Line: 3/8"; Liquid Line: 1/4"	
Drain Line (id.)	1/4" I.D	
Installation	Evaporator unit (fan coil unit) is installed through the cellar ceiling, condenser is installed up to 100 line ft. from the evaporator unit.	
Thermostat	Digital Control Display	
Temp. Delta	55°F max. temperature differential between the cellar and condenser air intake temperature.	
Warranty	2-year parts and labor	

# INTRODUCTION

## Customer Service

Thank you for purchasing a WhisperKOOL cooling system. We strive to provide the highest quality products and the best possible customer service. If you have any questions about your system, please call us at 1-800-343-9463 or visit [WhisperKOOL.com](http://WhisperKOOL.com).

## Using the Manual

This Owner's Manual is intended to assist in the proper maintenance of the cooling system. In order to ensure the longevity of your cooling unit, the equipment should be installed as outlined in this Owner's Manual. It is also vital to establish a proper care and maintenance schedule. Please read and review this Owner's Manual carefully and keep it for future reference.

## What is the WhisperKOOL Cooling System?

The WhisperKOOL cooling system is a specialized refrigeration system designed for one purpose only: to maintain the optimal temperature and natural humidity levels conducive to the proper storage and aging of fine wines. This system produces minimal in-cellar noise and has the most lenient exhaust requirements. An exterior housing is required for outdoor condensing unit installations.

## How Does the Cooling System Work?

Similar to the air conditioning systems used for homes, the evaporator and condensing units are installed in separate locations and are connected by a refrigerant line set. The evaporator portion is commonly installed in the wine cellar, with the condensing unit located either outside or in a remote indoor location that is ventilated. An exterior housing is required for outdoor condensing unit installations.

## Temperature Setting

The WhisperKOOL system can be set at any temperature within the acceptable wine-aging range of 50°F to 70°F. It is designed to cool up to 55°F cooler than the ambient temperature of the space to which the condensing unit is installed.

# WARRANTY REGISTRATION

In order to activate the warranty of your system, the Verification and Operational Documentation must be completed by the certified refrigeration technician installing your system and submitted via mail, fax or e-mail.

Mail to:  
WhisperKOOL  
ATTN: Warranty Registration  
1738 E. Alpine Avenue  
Stockton, CA 95205-2505  
USA

OR

Fax to:  
209-466-4606

OR

Scan and e-mail to:  
[warranty@whisperkool.com](mailto:warranty@whisperkool.com)

# RECEIVING & INSPECTING THE SYSTEM

## Receiving and Inspecting the System

- Lift only at the designated hand hold locations on the shipping container or fully support the unit from underneath. A shipment may include one or more boxes containing accessories.
- Inspect the packaging for any obvious signs of damage or mishandling before opening the container.
- Note any discrepancies or visual damage on the Bill of Lading before signing.
- Place the box containing the unit on a tabletop to prepare it for testing prior to installing.
- Sit unit upright for 24 hours.

**Note:** WhisperKOOL units are manufactured in the USA and tested prior to shipment.

## Review the Packing Slip to Verify Contents

- Check the model number to ensure it is correct.
- Check that all factory options ordered are listed.

**If any items listed on the packing slip do not match your order information, contact WhisperKOOL Customer Service immediately.**

## Check the Evaporator Unit (Fan Coil Unit) Box for the Following Contents:

- **Mini Ceiling Mount Evaporator Unit (Fan Coil Unit)**

### Accessory Kit#1:

- (1) Mini Ceiling Mount Owner's Manual
- (1) Split System Warranty Checklist
- (1) 50' Bottle Probe
- (1) Anti-Siphoning Device

### Accessory Kit#2:

- (1) Remote Keypad
- (1) 50' Keypad Connection Cable
- (1) Remote Box
- (1) Mounting Bracket

### Accessory Kit#3:

- (1) 1/4" Sight Glass
- (1) 1/4" Filter Drier
- (1) 10 ft. 1/4" Drain Line

### Accessory Kit#4 (Inside Kit #3):

- (12) #14 2" Phillips Pan Head Screw
- (1) 1/4" Drain Tube Connector
- (12) #8 x 3/8" Black Oxide Screws
- (2) 7/8" Hole Plugs
- (1) Small Strain Relief
- (2) Cable Ties
- (2) Cable Tie Holders
- (1) Strain Relief
- (1) Ratcheting Strain Relief
- (1) 1" Hole Plug

## Check the Condenser Box for the following contents:

- **Mini Ceiling Mount Condensing Unit**

Please leave the unit in its original box until you are ready for installation. This will allow you to move the product safely without damaging it. When you are ready to remove the product from the box, refer to the installation instructions.

**TIP:** Save your box and all packaging materials. They provide the only safe means of transporting/shipping the unit.



# BEFORE YOU START

1. **Inspect the system before installation.** If damage is found, please contact your distributor or WhisperKOOL Customer Service at 1-800-343-9463.
2. The condensing unit **requires a dedicated 115 volt 20 amp circuit.** Use a surge protector with the unit. **Do not use a GFI** (Ground Fault Interrupter) line.
3. It is **REQUIRED** to **install a drain line** to remove condensation from the evaporator unit.
4. The system is intended **for use in properly designed and constructed wine cellars.** Hire a professional wine storage consultant with a valid contractor's license to build your wine cellar.
5. WhisperKOOL requires that all Split Systems be installed by a certified HVAC-R technician only.
6. Warranty is not active until a Warranty Checklist has been received, reviewed, and approved.

If you encounter a problem with your WhisperKOOL system, please refer to the Troubleshooting Guide on page 40. If you have any further questions, concerns, or need assistance, please contact WhisperKOOL's Customer Service at 1-800-343-9463. Please be sure all testing has been completed prior to contacting Customer Service. Please have your results ready for your representative.

# PREPARING THE WINE CELLAR

The performance and life of your system is contingent upon the steps you take in preparing the wine cellar.

**Note:** Improperly preparing your enclosure or incorrectly installing your unit may cause unit failure, leaking of condensation, and other negative side effects.

## **IT IS HIGHLY RECOMMENDED THAT YOU OBTAIN THE ASSISTANCE OF A WINE STORAGE PROFESSIONAL.**

Wine storage professionals work with licensed contractors, refrigeration technicians, and racking companies to build well insulated, beautiful, and protective wine cellars. WhisperKOOL has provided useful tips to assist in the installation process. Our recommendations are meant to act as a guide in the process of building a proper enclosure. Your intended location may have specific needs that we do not address.

### **Wall & Ceiling Framing**

Build wine cellar walls using standard 2x4 or 2x6 construction methods and ceiling joists following the guidelines of local and state codes in your area. As a general rule, the thicker the walls and the higher the insulation value in your cellar, the better it will be at maintaining a consistent temperature.

### **Insulation**

Insulation is **REQUIRED** with the use of the WhisperKOOL product. Standard fiberglass or rigid foam insulation is normally used in cellar construction or, in some cases, "blown-in" insulation is used. It is very important that all walls and ceilings are insulated to keep the cellar temperature as consistent as possible during the summer and winter months. The R-value, or quality of insulation, is determined by the rate at which heat passes through the insulation. The higher the R-value, the more resistant the insulation is to conducting heat. Using higher R-values in insulation will lower your operating costs and unit run time. (R-13 minimum, R-19 recommended, R-30 for ceiling and exterior walls.)

### **Vapor Barrier**

Water vapor creates its own pressure (separate from the air pressure) and will intrude into colder/drier areas. A vapor barrier is **REQUIRED** to prevent the intrusion of water vapor so that the cellar can be kept at the correct temperature and humidity. 6 mil plastic sheeting (recommended) should be applied to the warm side of the cellar walls. The vapor barrier must also be applied to the outside walls and ceiling. If it is impossible to reach the outside, then the plastic must be applied from within the cellar. The most common method is to wrap the entire interior, leaving the plastic loose in the stud cavity so the insulation can be placed between each stud. All of the walls and ceiling must be wrapped in plastic for a complete vapor barrier.

In areas of high humidity, such as Southern and Gulf States, the vapor barrier will prevent infiltration of warm, moist air. The moist air can cause mold to form, and standing water in drain pans promote microbial and fungal growth that cause unpleasant odors and indoor air quality problems. If mold is found, remove it immediately and sanitize that portion of the unit.

**Note:** High humidity significantly increases the heat load on the cooling system.

Any break in the vapor barriers (cut, nail hole, over-lapping, etc.) will allow a moisture leak and must be sealed. The electric conduit is a "duct" for vapor to travel in. The conduit should be caulked and sealed on the warm air end.



### Unobstructed Airflow

Unobstructed airflow to and from the system is critical for the system's overall performance and life span. A minimum three-foot clearance (five-foot is ideal) area is crucial. The air blown by the fans needs to circulate and either dissipate or absorb heat from the space. The system will operate more efficiently with a greater amount of air to exchange.

**Note:** Avoid attempting to camouflage the unit. This will restrict airflow, and thus the system's ability to work efficiently.



### Door and Door Seal

An exterior grade (1 3/4") door must be installed as a cellar door. It is very important that weather stripping is attached to all 4 sides of the doorjamb. A bottom "sweep" or threshold is also required. The door must have a very good seal to keep the cool cellar air from escaping out of the cellar. One of the most common problems with cooling systems running continually is due to the door not sealing properly. **In cases where glass doors are used and the room size is close to the recommended system size, the next larger size WhisperKOOL system should be used.** This will compensate for the insulation loss due to the lower insulating rating of glass.

## Ventilation

The necessity of dissipating heat away from the condensing unit is critical to the performance and cannot be overstated. As the system operates and cools, a greater amount of heat is generated on the condensing side of the system. Adequate ventilation is required in order to dissipate heat away from the condensing unit. If ventilation is inadequate, the exhaust will heat the area or room and adversely affect the system's ability to cool. In some cases, it may be advisable to install a vent fan to dissipate heat within the exhaust area on the condensing side of the system. However, you must have a fresh air inlet as well.

**Note:** If you are unsure about having adequate ventilation in your install location, please contact us to assess your specific installation at [support@whisperkool.com](mailto:support@whisperkool.com) or 1-800-343-9463.



**Note:** The unit comes black. The mounting bracket and front grille are paintable, enabling you to match your desired color.

## Ambient Temperature Factor

The cooling system has the ability to cool a wine cellar efficiently to 55°F as long as the ambient temperature of the area that it is exhausting to does not exceed 110°F. Therefore, you want to exhaust the condensing unit in a space which will not exceed 110°F and will allow for proper dissipation of the heat exhausted by the condensing unit. Without proper heat dissipation the system will not have the capacity to keep the wine at a desirable 55°F.



**WARNING! allowing your system to operate in high ambient temperatures for extended periods of time will greatly decrease the life of your system and void your warranty. The cooler the temperature of the air entering the condenser coil, the more cooling capacity the system has. The less heat gain through the common wall, the lower the consumption of electricity.**



# PREPARING THE INSTALLATION LOCATION

Minimum Tools Needed:

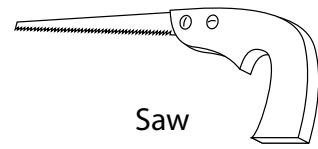
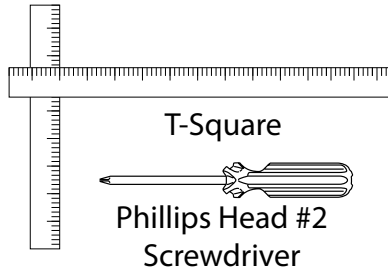
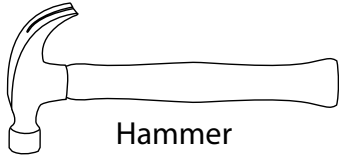

Locate the desired installation location. Using a stud finder, locate the ceiling joists on either side of the center point. Cut and frame an opening in the ceiling measuring 12" x 22.75". **Make sure the framing is sufficient to support the weight of the cooling unit. It is highly recommended to use only the mounting locations provided. These locations ensure that the installer will not drill into any copper or electrical within the system.**

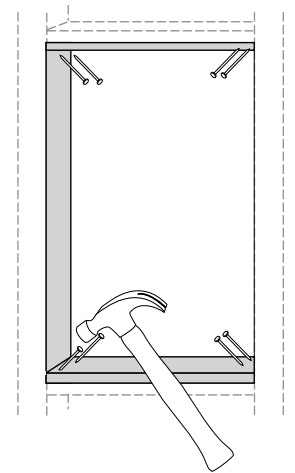
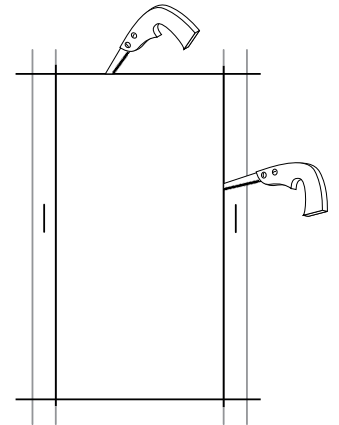
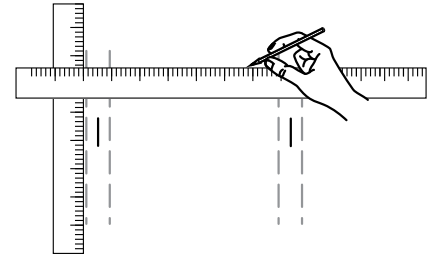

Flush Mount  
Mounting Option

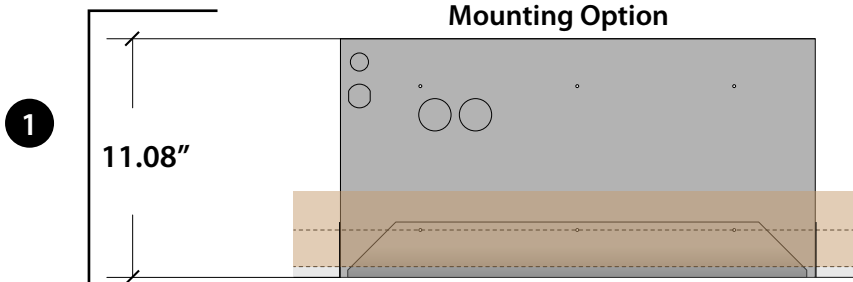

Partially Recessed  
Mounting Option

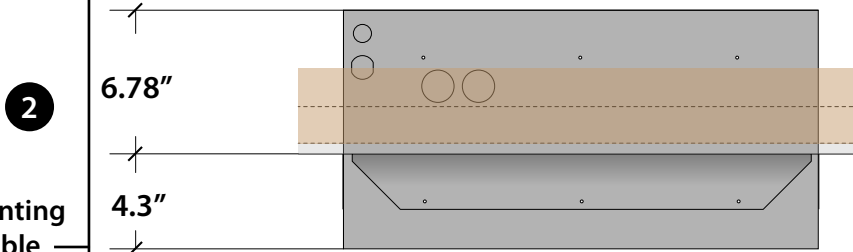

Fully Recessed  
Mounting Option

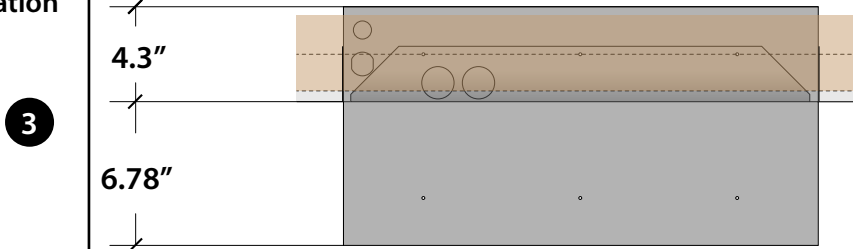

Fully Exposed  
Mounting Option

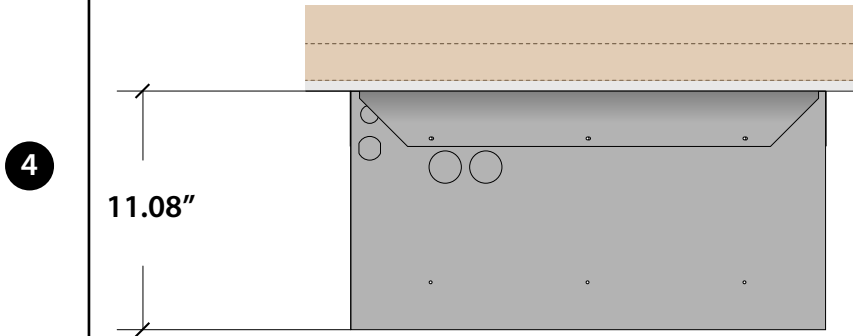

Choose a Mounting  
Option suitable  
for the installation  
location.

# SYSTEM WIRING AND CONNECTIONS

## ITEMS TO ROUTE BEFORE INSTALLING THE EVAPORATOR

1. Route the line set from the condensing unit to the desired evaporator installation location.
2. Route the keypad cable from the desired keypad location to the evaporator installation location (see page 22 for more keypad information).
3. Route the bottle probe cable from the desired thermostat bottle location to the evaporator installation location (see page 21 for more bottle probe information).
4. If you have purchased a unit with the Active Humidity Option, route the water line from the water source to the evaporator location (see page 23 for more Active Humidity Option Information).
5. If you have purchased a unit with the Active Humidity Option, route the humidistat cable from the desired humidistat location to the evaporator installation location (see page 22 for more Humidistat Information).
6. Route the drain line from a proper discharge location to the evaporator installation location (see page 20 for more drain line Information).
7. Route the power cable wiring to the evaporator installation location.

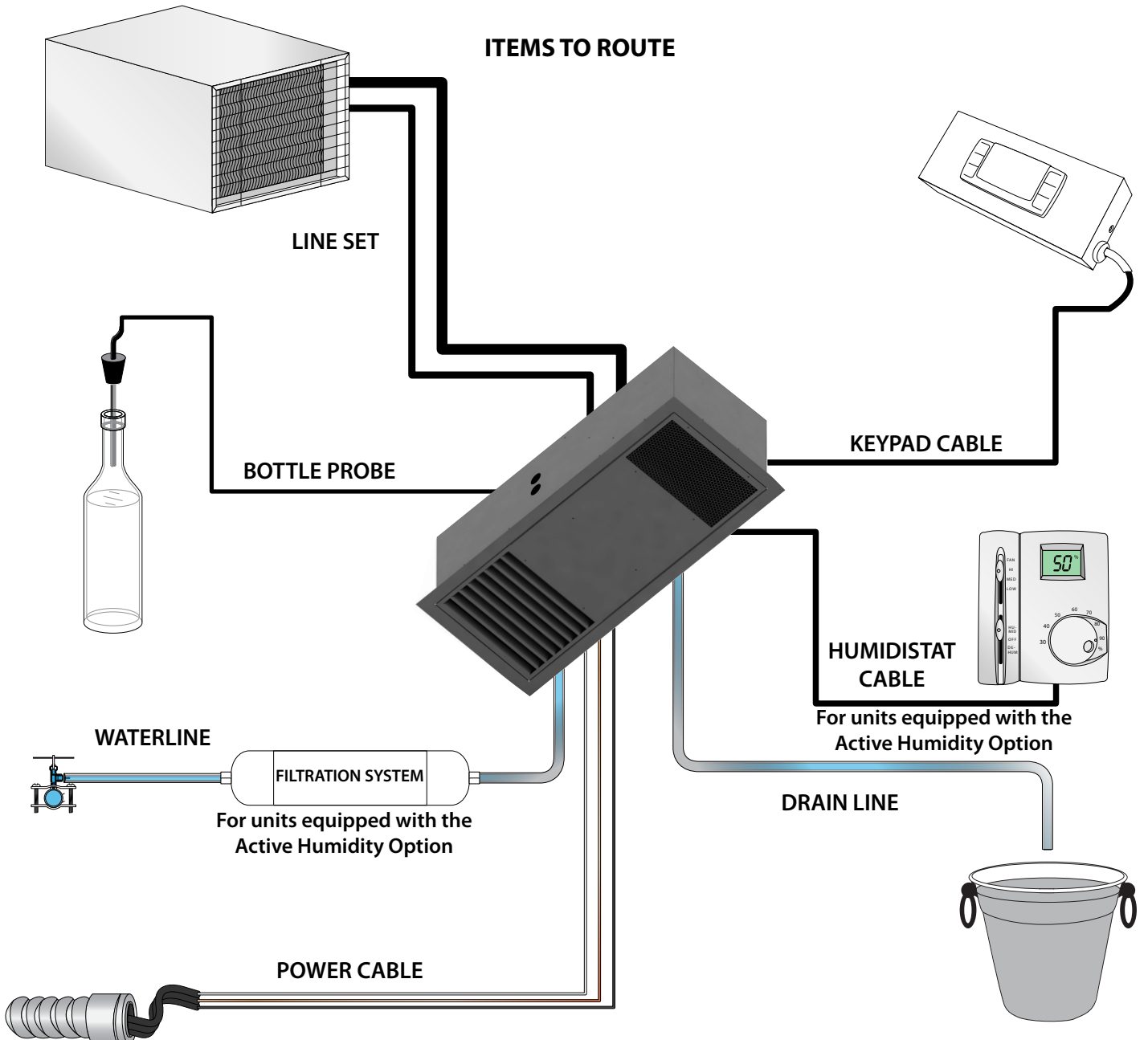

# INSTALLING THE EVAPORATOR UNIT

## Single Piece Mounting Bracket

The mounting bracket has been designed to secure the unit to the ceiling. Install the mounting bracket to the evaporator unit following the guide below.

## Mounting Bracket Installation

Using the guide below, select the desired mounting orientation and slide the mounting bracket onto the unit. Align the mounting holes on the mounting bracket with the pre-drilled holes on the unit. Fasten the mounting bracket to the unit using the supplied 1/2" self-tapping screws. Slide the unit through the framed opening in the ceiling. Secure the unit to the opening using the 12 supplied 1 3/4" hex head screws.

**Note: It is highly recommended to use only the mounting locations provided. These locations ensure that the installer will not drill into any copper or electrical within the system.**

1. Secure the mounting bracket to the unit.

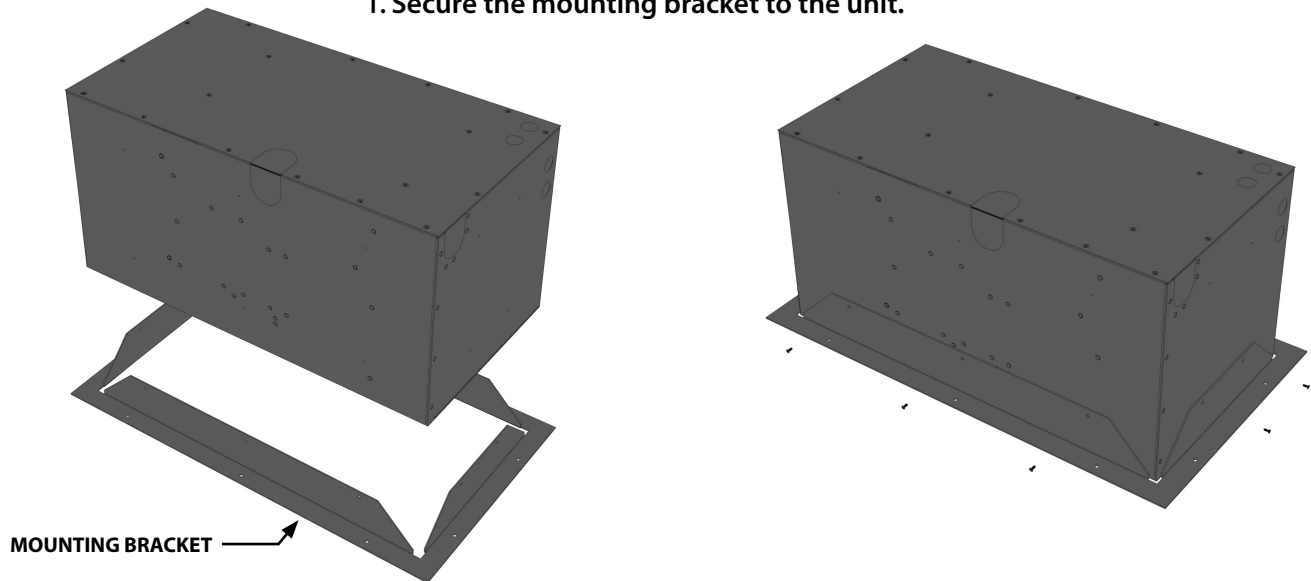

**Note: It is highly recommended to use only the mounting locations provided. These locations ensure that the installer will not drill into any copper or electrical within the system.**

2. Secure the unit's mounting bracket to the opening using the 12 supplied 1 3/4" hex head screws.

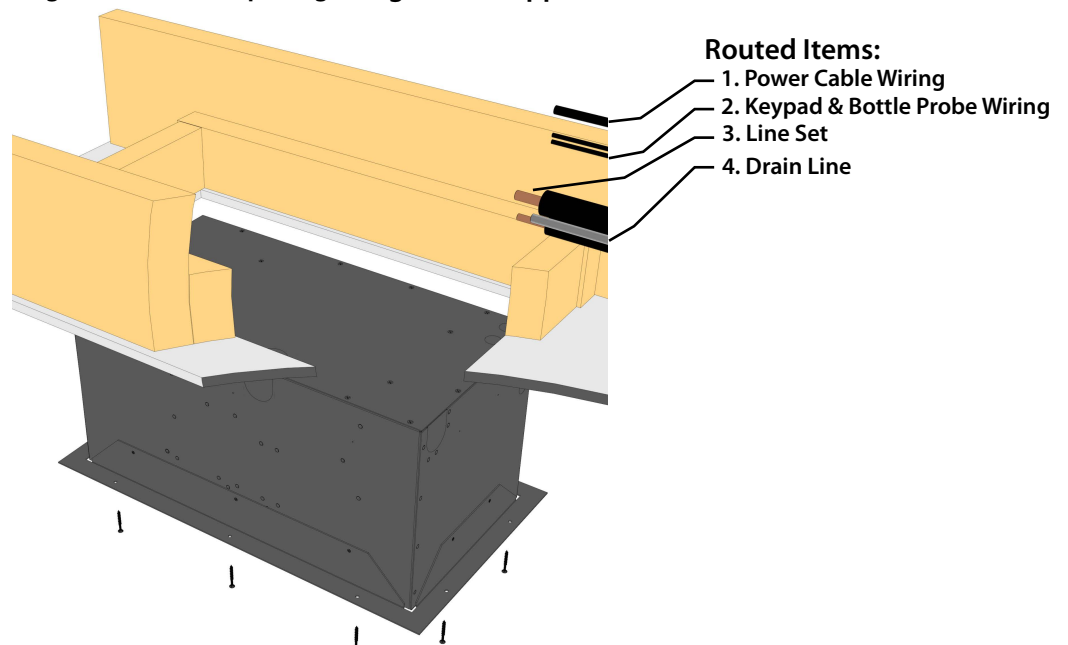

# INSTALLING THE EVAPORATOR UNIT

## CONNECTING THE EVAPORATOR UNIT

1. Unscrew the 16 screws and remove the Top Access Panel.

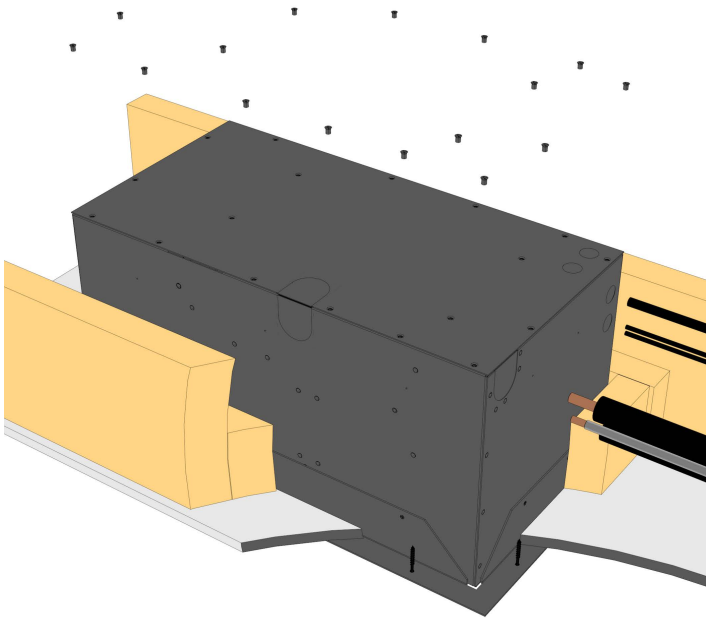

2. Remove the Knockout(s) that you will be using to route the items on page 12 into the unit (power cable wiring, keypad cable, bottle probe cable, and humidistat cable is optional).

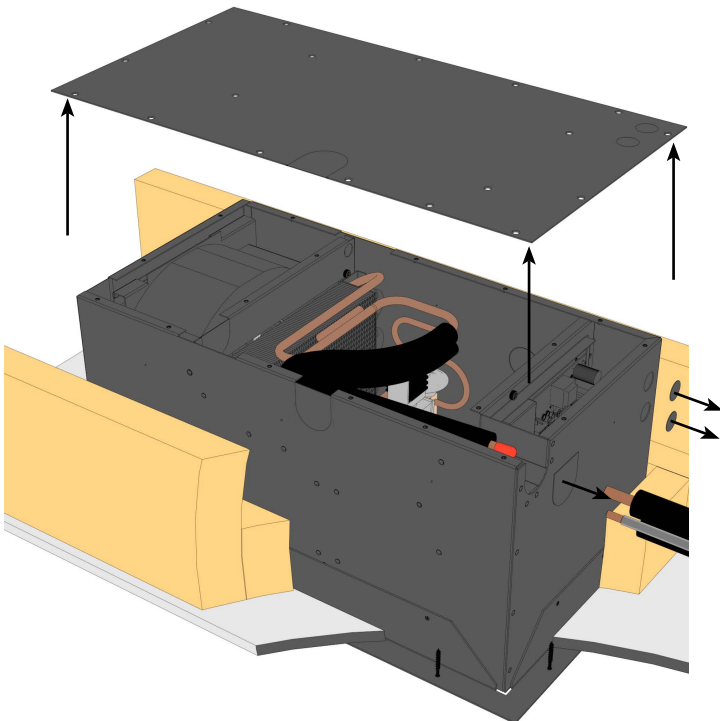

3. Route the wiring into the unit as shown below.
4. Pull out the line set through the knockout by bending the tubing away from the coil as shown in the image below.
5. Route the drain line out of the evaporator unit with the line set.

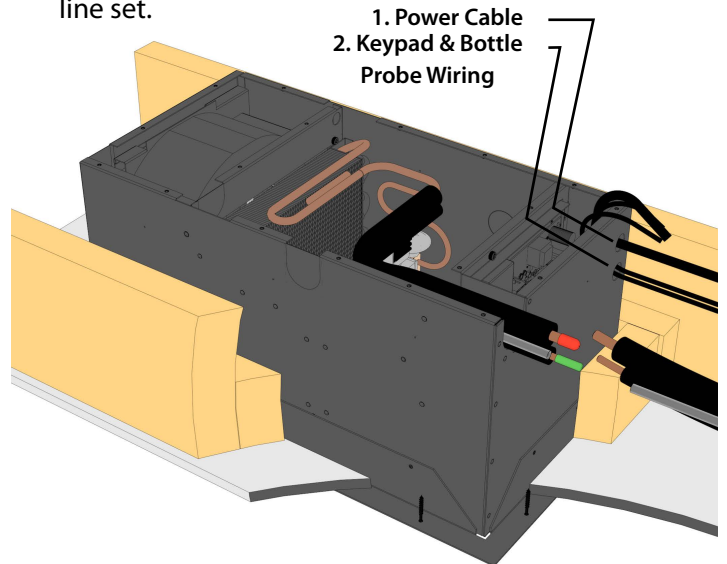

6. Remove the thumbscrew holding the electrical panel and slide the panel.

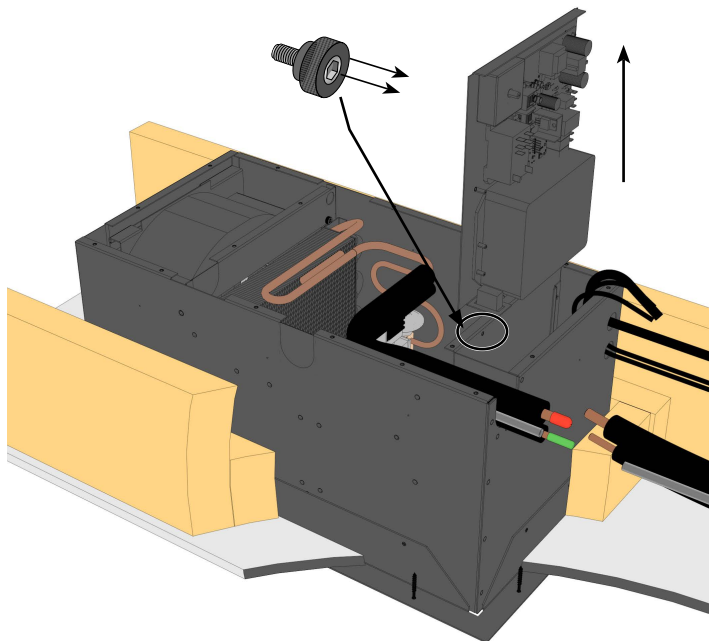



# INSTALLING THE EVAPORATOR UNIT

7. Connect the power cable to the evaporator.
8. Connect the keypad cable to the evaporator (see page 22 for more keypad information).

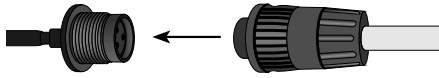

9. Connect the bottle probe cable to the evaporator (see page 21 for more bottle probe information).

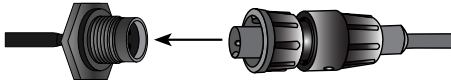

10. If you have purchased the Active Humidity Option, connect the Humidistat cable to the evaporator (see page 24 for more humidistat information).

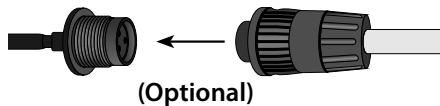

11. Slide the electrical panel back into the evaporator unit and secure with the thumbscrew.
12. If you have purchased the Active Humidity Option, connect a water line to the water connection port on the evaporator unit, shown in Figure 5 (see page 23 for more Active Humidity Option Information).

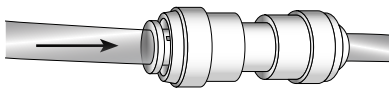

**Figure 5 (Optional)**

13. Remove the protective caps from the liquid and suction line connection tubes. (as shown below)

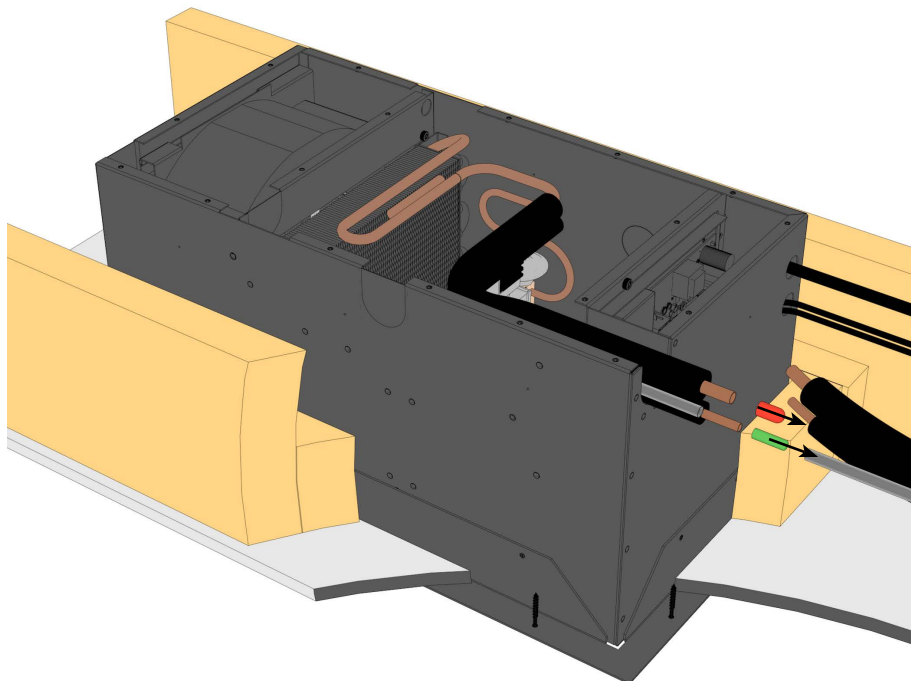

## INSTALLING THE EVAPORATOR UNIT

- Using 1/4" and 1/2" copper tubing, route the liquid and suction lines through the knockouts in the wrapper. Note: 1/2" copper tubing will slip over the 3/8" suction line on the evaporator for an easy connection.
- Place a wet rag around the suction and liquid lines approximately 4" from the braze joints. This will prevent excess heat from damaging components.
- To prevent oxidation, purge nitrogen through the system.
- Braze the copper tubing to the connections on the evaporator unit.

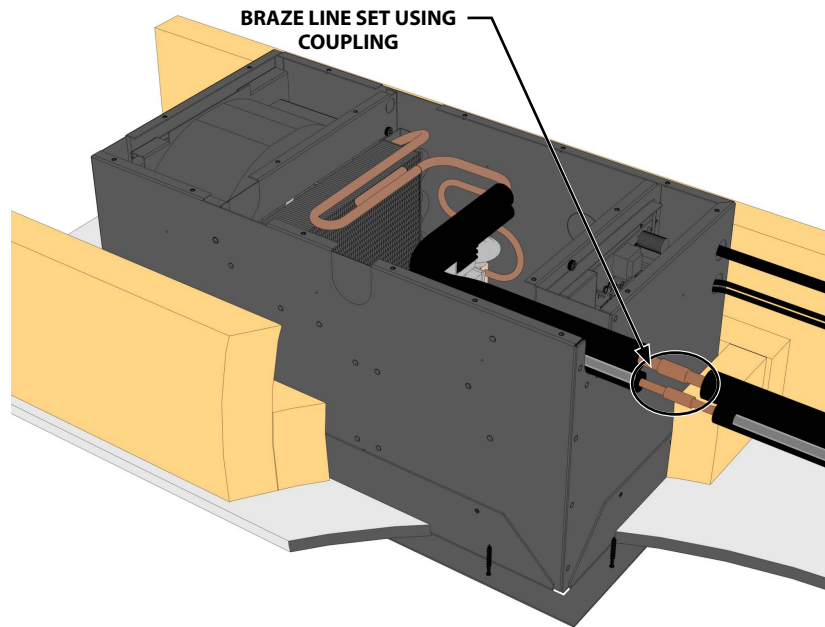

- Insulate the suction line using Armaflex or similar insulation.
- Connect the drain line using the Anti-Siphon Device following the directions on page 20.
- If you have purchased the Active Humidity Option, route the 1/4" water line out of the evaporator unit with the drain line.

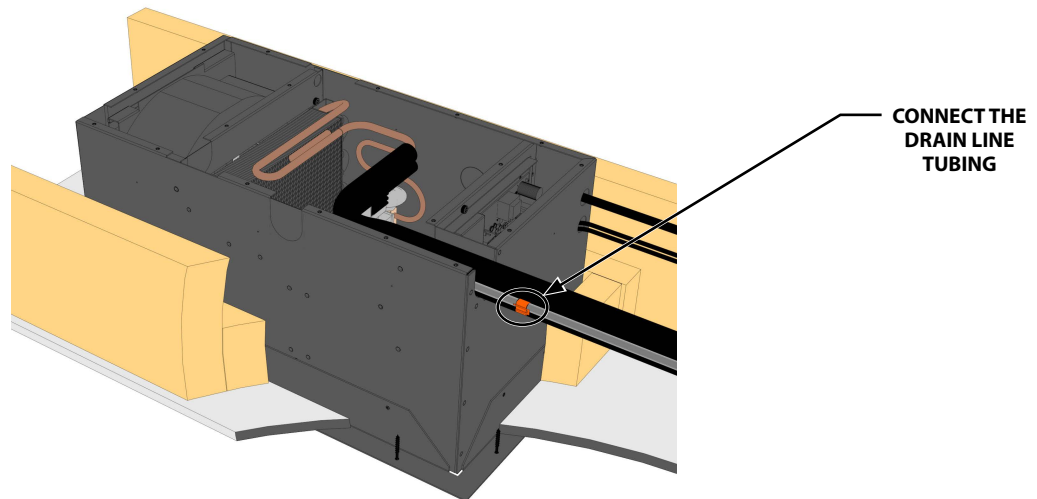

- Reinstall the Top Access Panel and fasten the 16 screws into place.
- Seal all gaps around the unit using expanding foam.
- Using fiberglass insulation, wrap any part of the wrapper that is not inside the cellar. This will prevent condensation from forming on the wrapper.**
- If desired, paint the mounting bracket and Front Access Panel to match the color of the ceiling.**

# ELECTRICAL PANEL ACCESS

1. Remove the 8 screws securing the faceplate into place.

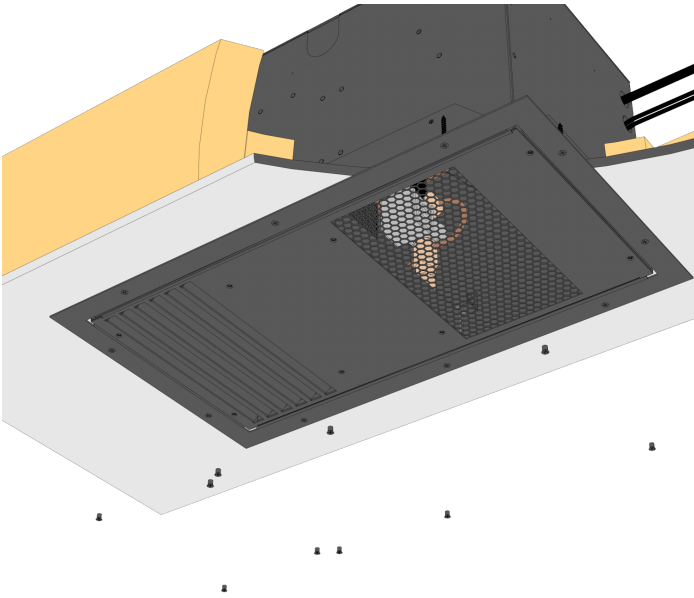

2. Remove the faceplate and the thumb screw to release the Electrical Panel.

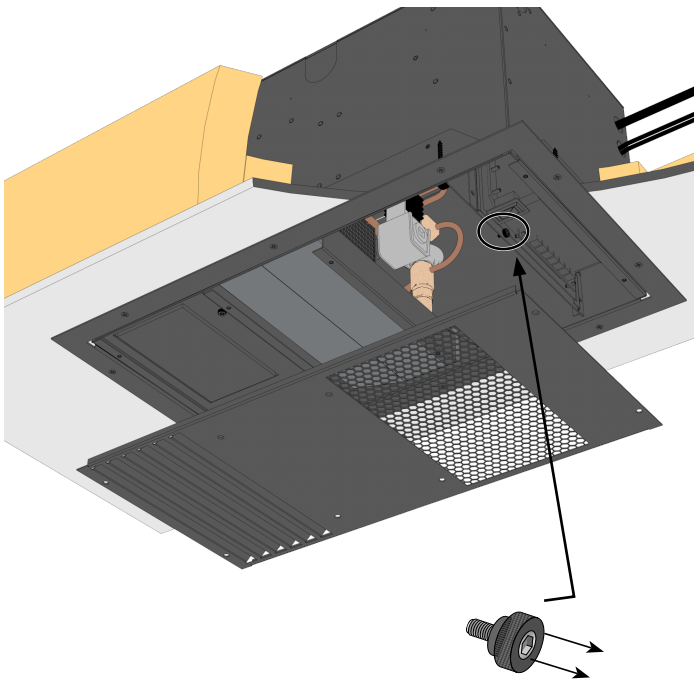

3. Leave slack on the wiring to enable the access panel to slide out.

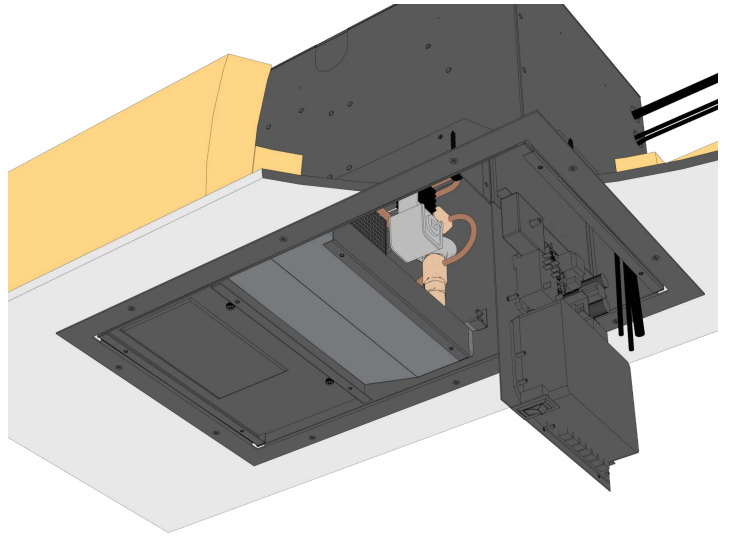

# REROUTING LINE SET

## Rerouting the Line Set Through the Desired Knockout

1. Cut the Armaflex and copper lines as shown in the image below.
2. Route the Line Set through the desired knockout.
3. Using 1/4" and 1/2" copper tubing, route the liquid and suction lines through the knockouts in the wrapper. Note: 1/2" copper tubing will slip over the 3/8" suction line on the evaporator for an easy connection.
4. Place a wet rag around the suction and liquid lines approximately 4" from the braze joints. This will prevent excess heat from damaging components.
5. To prevent oxidation, purge nitrogen through the system.
6. Braze the copper tubing to the connections on the evaporator unit.
7. Insulate the suction line using Armaflex or similar insulation.

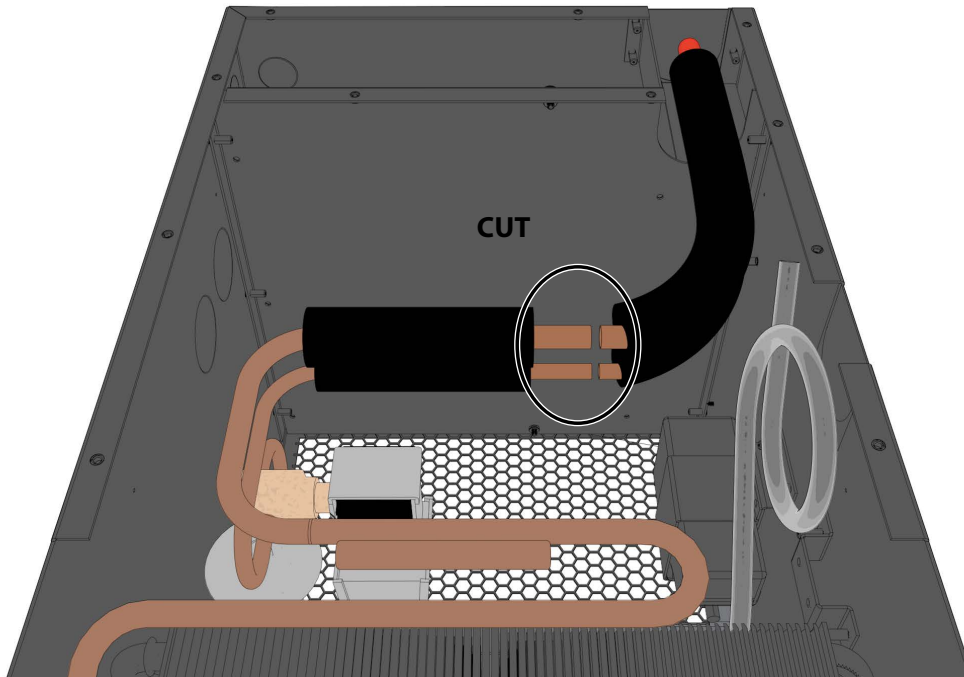

**Note:** Line Set and drain line should extend to the exterior of the unit through the Knockout(s). Dimensioned Locations of the knockouts are provided on page 3.

# 220V CONNECTION FOR MINI CEILING MOUNT EVAPORATOR UNIT

**NOTE:** These Instructions are only for units equipped with the 220V option selected at time of purchase.

1. Connect the supplied power cord with the exposed wire ends to the evaporator unit following the wiring instructions in this Owner's Manual.
2. Plug the power cord into one of the outlets labeled 110V on the transformer.

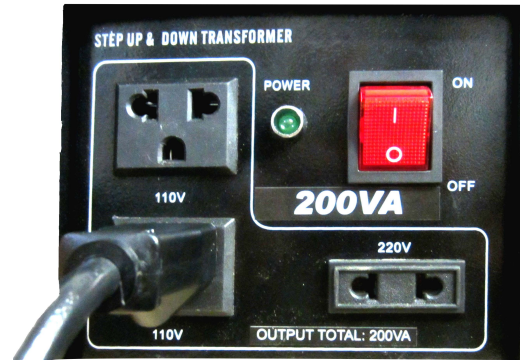

3. On the back of the transformer make sure that the switch is set to 220V.

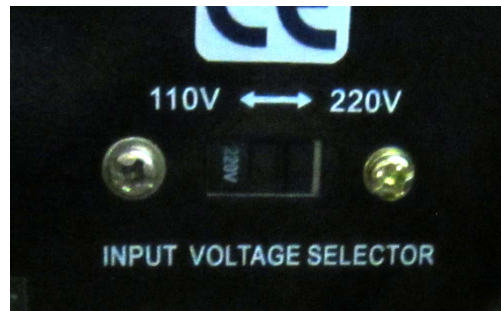

4. Plug the transformer in to a 220-230V power source.
5. To apply power to the unit move the switch on the front of the unit to the "on" position.

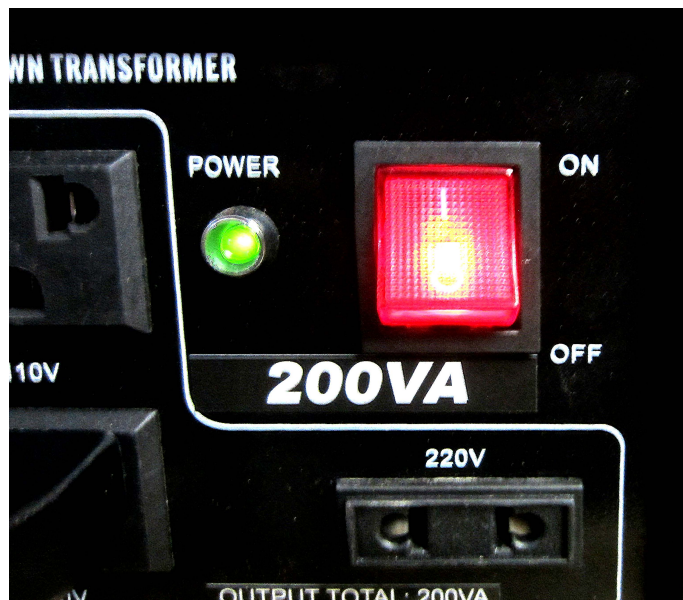

# DRAIN LINE

## Condensation Drain Line

The condensation drain line tube is used to remove excess condensation from the unit to a proper discharge location. It is important that the drain line tube is properly connected.

**Failure to use the condensation drain line tube will void the warranty on the unit.**

## Drain Line

The Mini Ceiling Mount evaporator features a drain line pump system that removes excessive condensate build up in the drain pan. During operation, the drain pan collects water that drips from the coil. The drain line pump system will prevent overflow and leaking by allowing for discharge of the additional condensate.

The longevity of the drain line pump may be compromised if the system operates dry. To prevent the pump from starting dry an anti-siphon device must be installed in the drain line tubing as shown in Figure 9. This device should be installed in the drain line post pump on the exterior of the evaporator unit. WhisperKOOL recommends to install the anti-siphon device relatively close to the evaporator because water will remain between the pump and the device.

**NOTE:** The anti-siphon device only needs to be used when the drain line is routed below the level of the evaporator unit. In this case the anti-siphon device should be installed in the drain line at the level of the evaporator unit.

## Connecting the Drain Line

Route the drain line to an appropriate discharge location using the supplied barb coupling and 1/4" tubing.

Do not route the drain line more than 30 vertical ft.

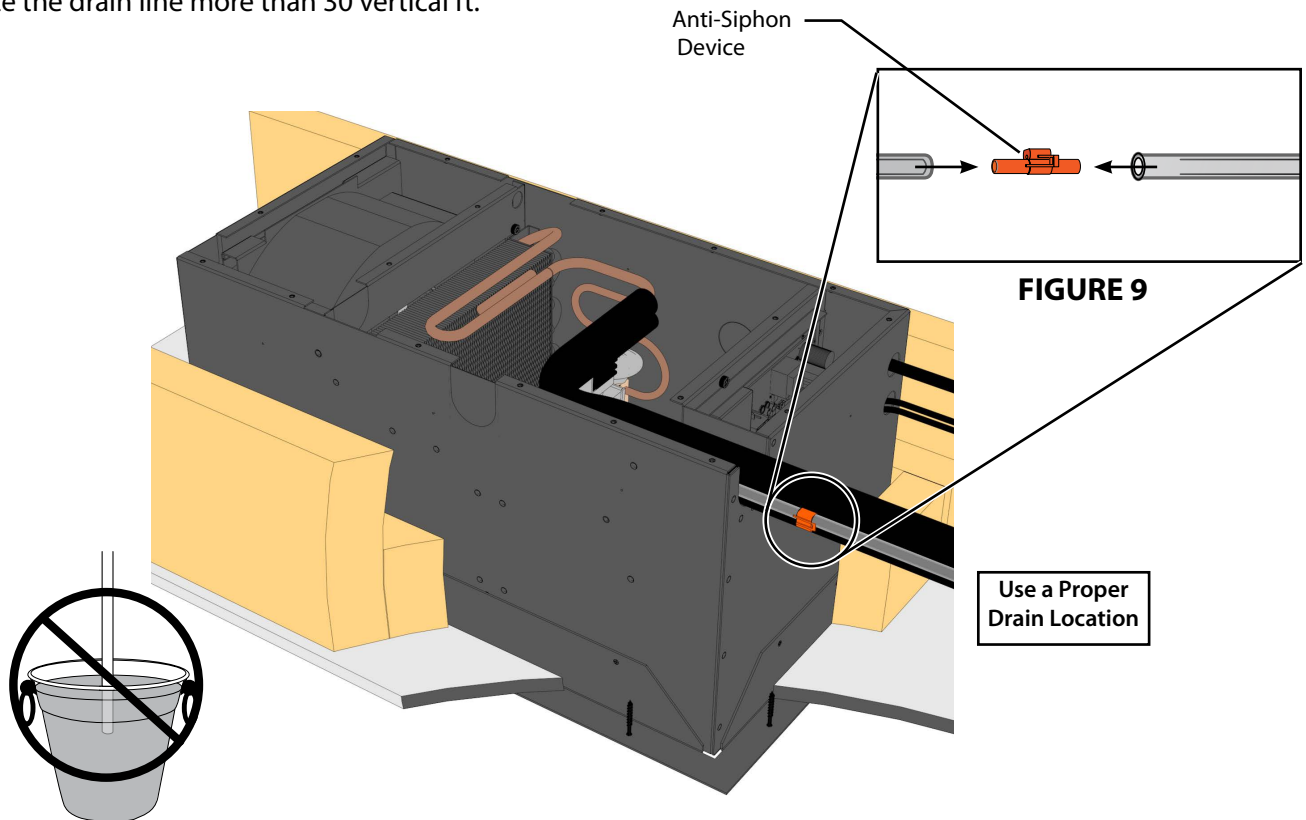

**WRONG:** Drain line is under water.

**To prevent mold from growing, allow the drain line to hang above the water line.**

**Note:** Water will remain between the pump and the anti-siphon device at all times.

# LIQUID TEMPERATURE - MEASURING THERMOSTAT

The WhisperKOOL Series cooling units come equipped with a liquid temperature measuring thermostat. This incorporates the following advantages:

1. Wine is kept in a very precise, controlled environment. This assures a consistent temperature.
2. By measuring liquid rather than air, the cooling unit is protected from rapid cycling caused by fluctuations in air temperature.

## Liquid Temperature - Measuring Thermostat

To assure a consistent temperature, place bottle probe at least 3 feet away from the air output and not in the flow of the air.

### To Use the thermostat:

1. Locate an empty wine bottle.
2. Fill 3/4 full with room temperature tap water.
3. Place bottle probe securely into bottle.
4. Place bottle with probe level and to the side of the unit in your wine cellar. ***It is recommended that it be placed in a central location of your wine cellar.*** Avoid pulling too much on the probe cord. It may become disconnected resulting in non-operation of the unit.

**Note:** The thermostat can be set between 50°F and 67°F.

**Remember:** The WhisperKOOL unit operates based on the temperature of the water. Do not be misled by thermostats reading air temperature. The air temperature in the cellar will be cooler than the liquid temperature of the wine while it is reaching optimum balanced temperature.

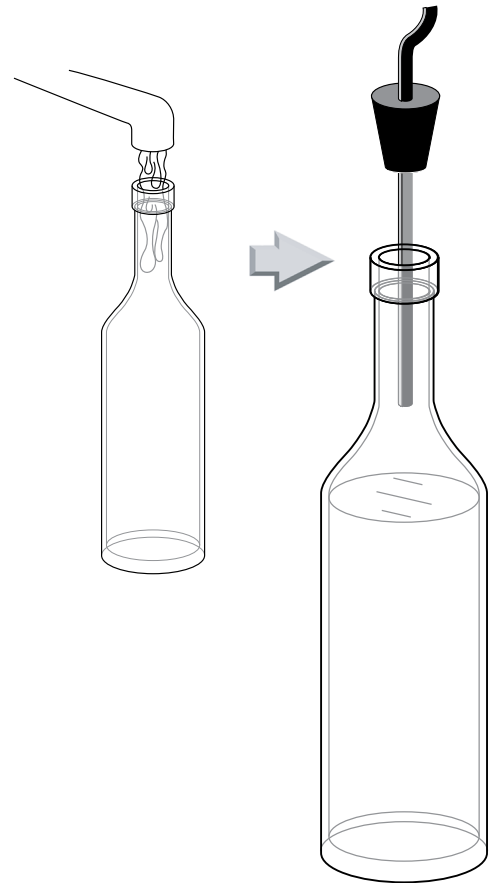

# REMOTE KEYPAD: INSTALLATION AND CONFIGURATION

**Note:** A 50ft communication cable is included and the keypad can be installed up to 300 feet away from the evaporator unit. Longer lengths can be ordered by calling 1-800-343-9463 ext. 751.

Route the communication cable from the evaporator unit to the desired keypad location. Remove the wall mount bracket from the display housing. Using appropriate anchors or fasteners, secure the wall mount bracket to the wall. If routing the communication cable through a wall, connect the wires to the back of the control panel following the image below. Connect the red wire to the upper (+) terminal. Connect the black wire to the lower (-) terminal. If the communication cable is not routed through the wall; remove the plug in the side of the display housing. Route the cable through the hole and connect to the back of the display as shown below. Reattach the keypad box to the bracket.

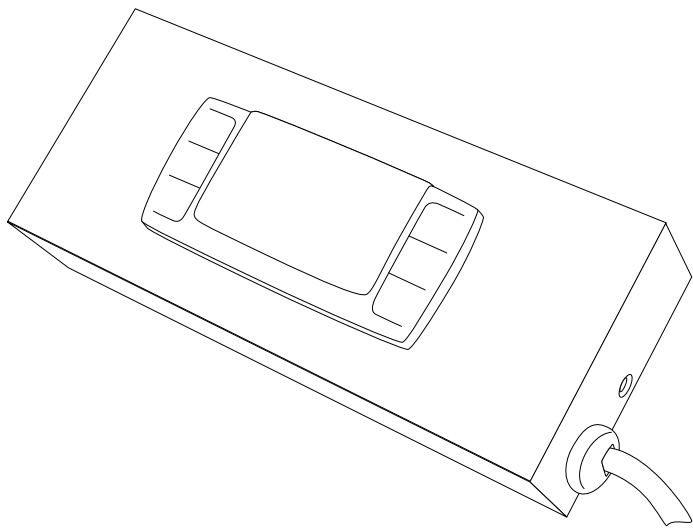
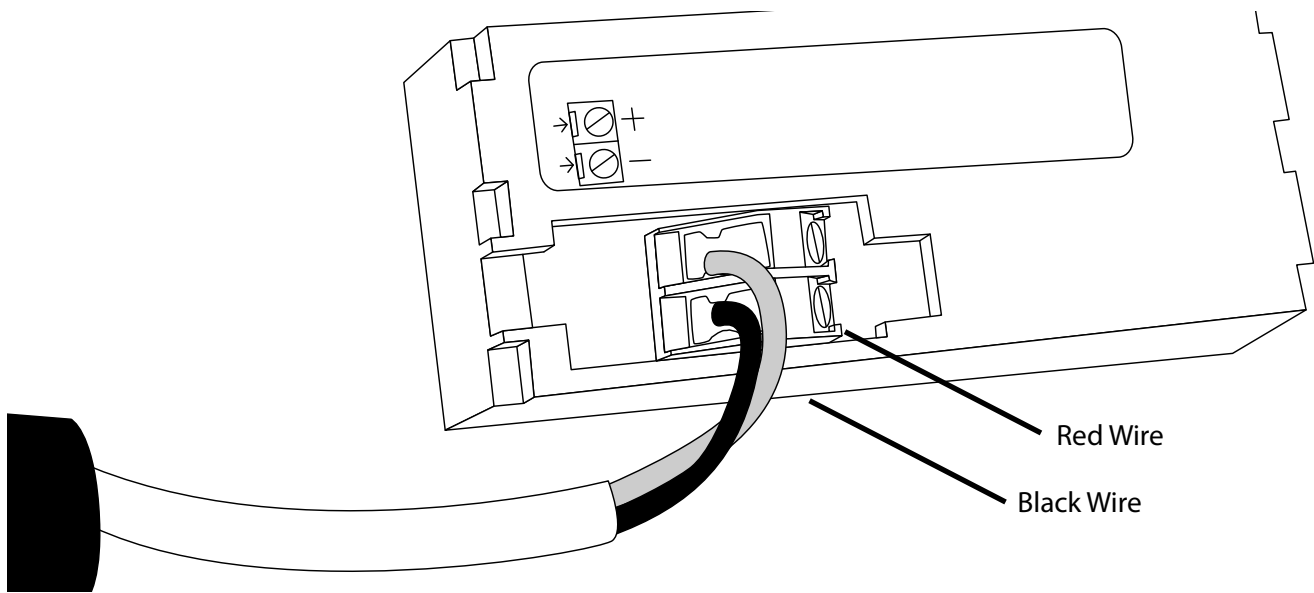

Connection wire in Side Mount configuration

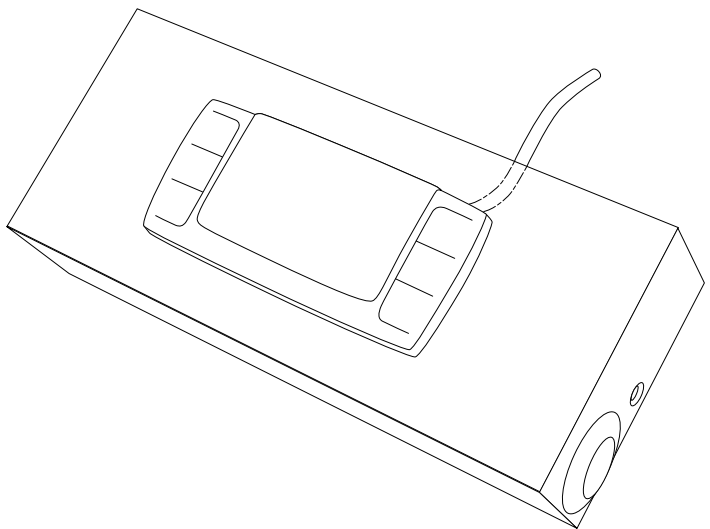

Connection wire in Rear Mount configuration



# ACTIVE HUMIDITY OPTION OVERVIEW

## ACTIVE HUMIDITY SPECIFICATIONS

dBa	58.5
Humidistat Range	30-90% RH
Humidistat Accuracy	± 1%
Humidistat Adjustment Increments	1%
Water Supply Feed Rate	0.63 gph @ 40 psi

### Accessory Included with Active Humidity Option:

- (1) 25 ft. Humidistat Cable
- (1) Dayton Humidistat

### Use of the Active Humidity Option

Humidity may fluctuate in the wine cellar. The Active Humidity Option stabilizes the environment by adding moisture when the humidity levels drop below your desired level. Using a humidistat and a water source, the Active Humidity Option is able to regulate and establish a humid environment suitable for wine storage.

**Note:** The ideal humidity of a wine cellar is between 50-70%.

### General Active Humidity Option Recommendations

- Water source needs to have at least 40 psi.
- Water tubing size: 1/4" O.D.
- Water source should be tested for content and characteristics.
- In areas that are known to have hard water, the use of a water softener system is required.

**Note:** Failure to install a water softener or a filtration system will allow an excessive particle residue buildup and may lead to system failure.

- Even if the area is not known to have hard water, the use of a filtration system (particle filter) is required.
- Clean the evaporator coil every 3 months to remove particle residue buildup.
- It might be best to use a self-piercing saddle valve as a simple connection to a water source.
- Clean or replace the Misting Nozzle every 12 months.

**Do not** allow water leakage inside of the Unit.

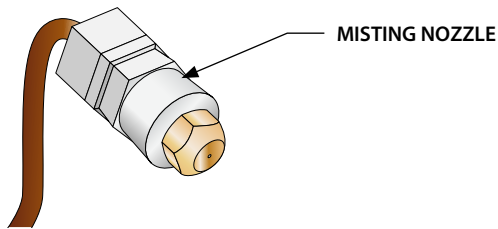

### Self-Piercing Saddle Valve

Install a Self-Piercing Saddle Valve to a nearby water supply for simple connection to a water source as shown in Figure 1.

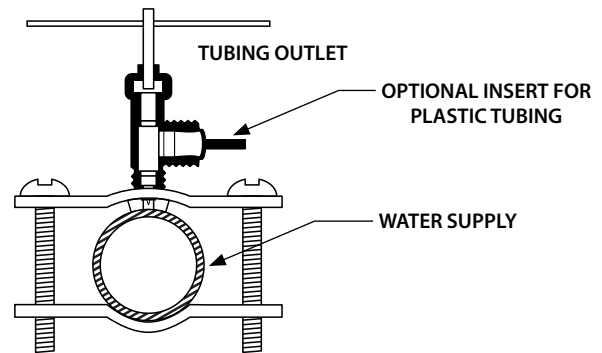

**Figure 1**

### Water Flow Order

- The water supply should pass through either a water softener or a Filtration system before reaching the unit as shown in Figure 2.
- Route a 1/4" Copper, Pex, or equivalent tubing from the water source and connect to the water inlet fitting on the unit as shown in Figure 3.
- Turn on the water and check for leaks.

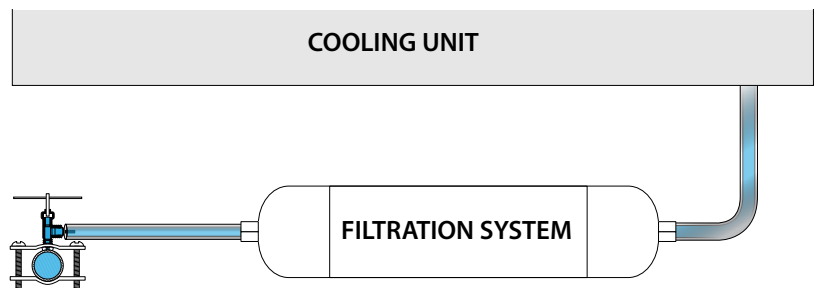

**Figure 2**

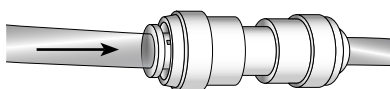

**Figure 3**

# HUMIDISTAT INSTALLATION

Only a 120-Volt humidistat can be used with this unit.

## Routing the Wiring

1. Plug the circular connector from the humidistat cable into the circular connector on the unit as shown in **Figure 1**.
2. Route the wire from the unit to the desired humidistat location.

**Figure 1**

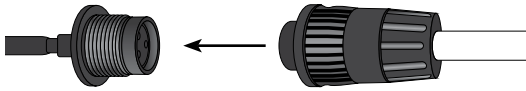

## Removing the Cover

1. Move both slide controls to the bottom position.
2. Use a screwdriver to loosen the screws at the bottom of the humidistat as shown in **Figure 2**.
3. Carefully remove the cover as shown in figure **Figure 3**.

**Figure 2**

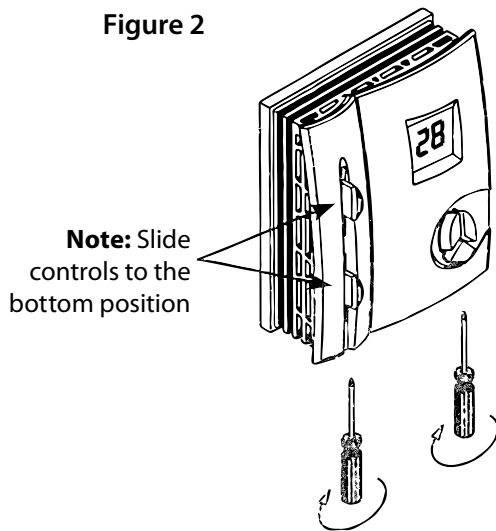

**Figure 3**

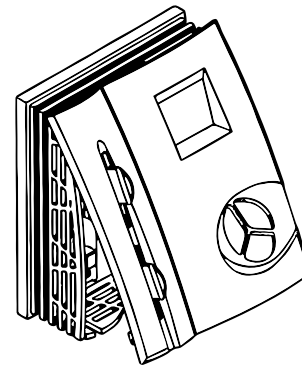

## Mounting Without a Wall Mount Plate

4. Make sure the humidistat electrical is unplugged before installing the unit.
5. Position the back half of the humidistat cabinet on the wall or junction box to ensure it is level and covers the junction box completely.
6. Pull the electrical wires through the hole at the terminal block of the humidistat.
7. Drill holes in the wall through the two mounting holes in the back of the humidistat cabinet as shown in **Figure 4** and insert anchors into the holes.
8. Fasten the humidistat to the wall with screws through the mounting holes.

**Figure 4**

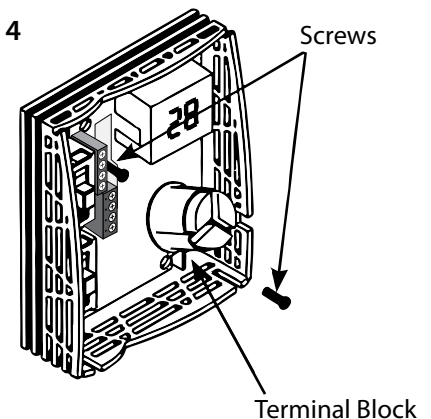

## Mounting With a Wall Mount Plate

1. Make sure the humidistat is unplugged before installing the unit.
2. Position the wall mount plate on the wall or junction box to ensure the plate is level and covers the junction box completely.
3. Pull the electrical wires through the hole in the wall mount plate.
4. Drill holes in the wall through the two mounting holes in the back of the wall plate as shown in **Figure 5** and insert anchors into the holes.
5. Pull the electrical wires through the hole at the terminal block.
6. Fasten the wall plate with two screws through the mounting holes.
7. Fasten the humidistat to the wall plate with screws through the mounting holes.

**Figure 5**

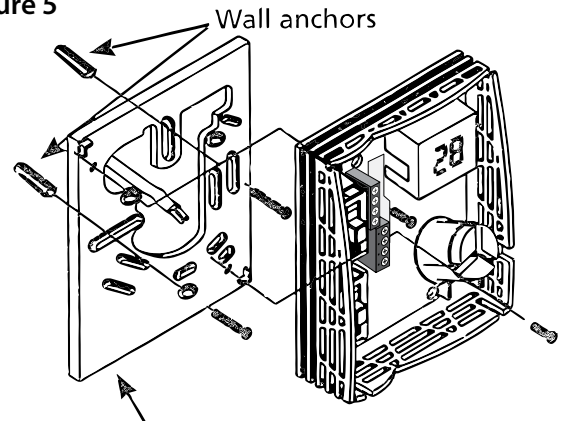

**Figure 6**

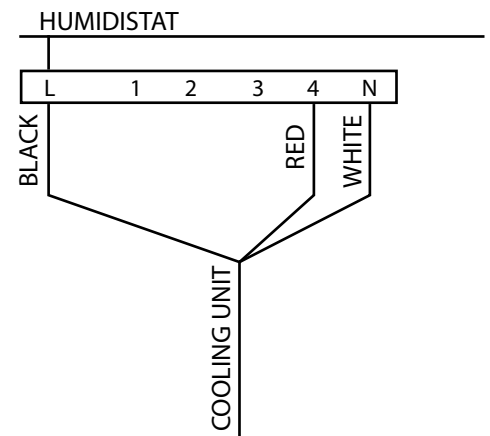

## Electrical Connection

1. Connect the electrical wires to the corresponding terminals on the terminal block following the circuit diagram inside the top cover of the unit, see **Figure 6**.
2. Connect the white wire to the N terminal, the red wire to the 4 terminal, and the black wire to the L terminal on the humidistat.

## Reattaching the Cover

1. Move both slide controls to the bottom position.
2. Align the humidistat rubber buttons with the holes in the cover as shown in **Figure 7**.  
*Note: If the controls are not lined up when the faceplate is being reattached, then the controls may become stuck. In order to reattach the faceplate correctly move the slide controls to the bottom position.*
3. Carefully attach the top cover. Ensure the cover locks in place by pushing down on the top of the faceplate and then pushing inward toward the wall.
4. Attach the screws at the bottom of the cover and tighten into place as shown in **Figure 8**.

**Figure 7**

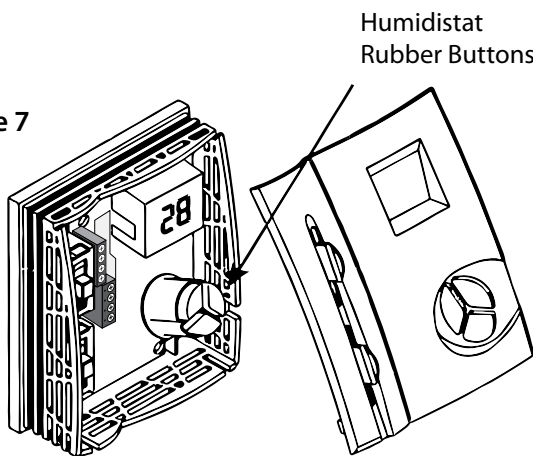

Make sure the rubber buttons align with the holes in the cover.

**Figure 8**

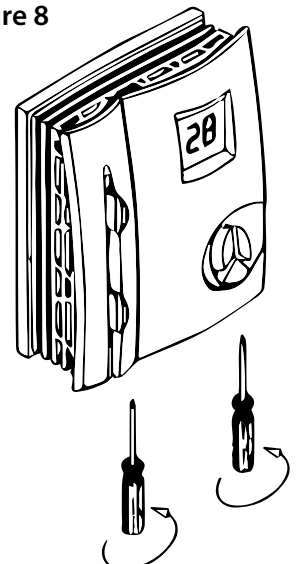

## Correct Humidistat Settings

1. Use the UP or DOWN arrow to reach the desired humidity level on the display and press ENTER.
2. Set the top selector switch to the HUMID setting.
3. Set the bottom selector switch to the OFF setting.

# MINI CEILING MOUNT WIRING DIAGRAM

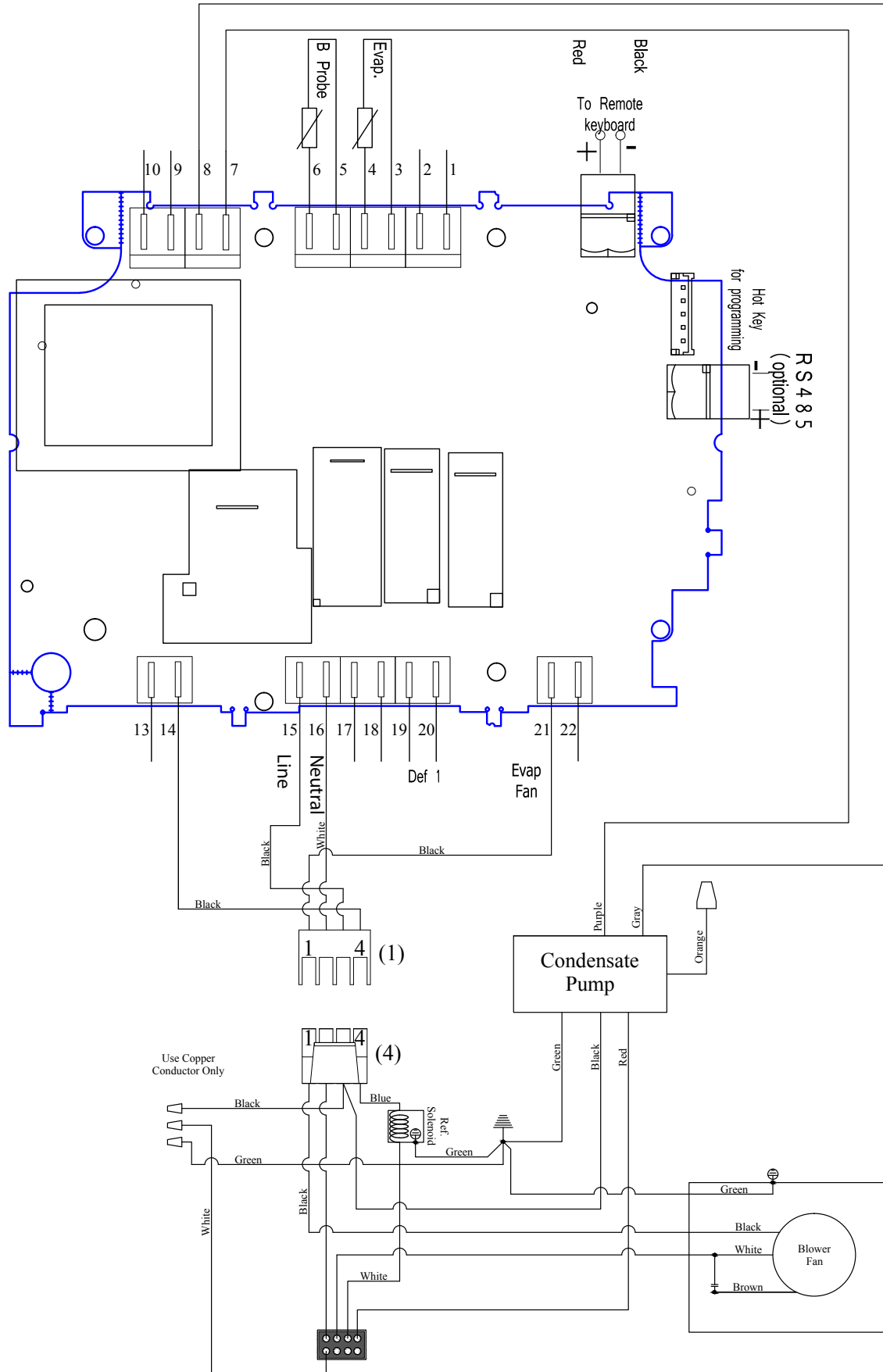

# MINI CEILING MOUNT WITH HUMIDITY WIRING DIAGRAM

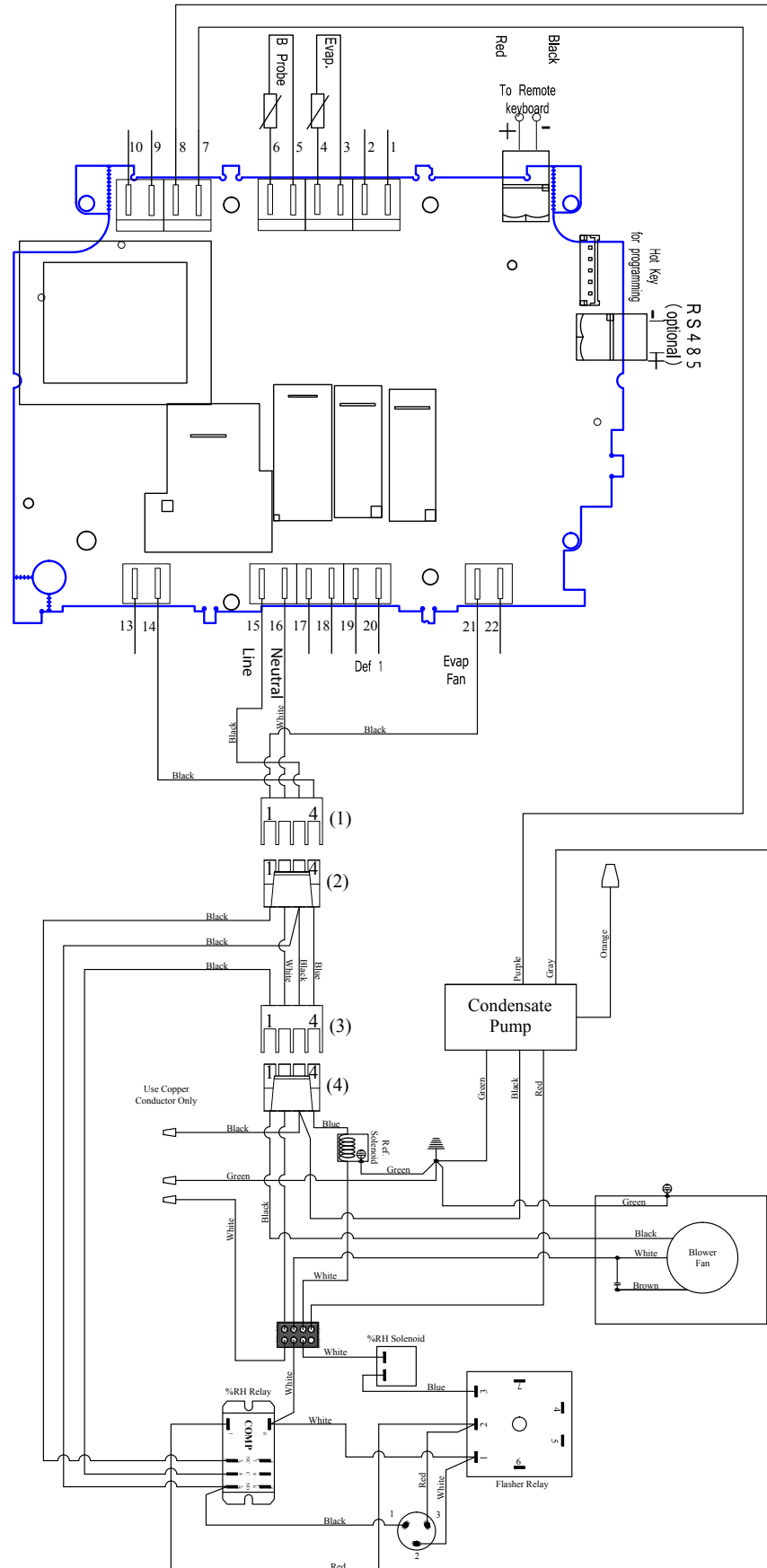

# PREPARING THE CONDENSING UNIT

## Electrical Needs

**The Condensing Unit requires a dedicated 115V, 20 amp circuit.** The unit draws a large inrush current for about 1 second the instant the compressor starts. With a dedicated circuit and circuit breaker, the Condensing Unit will have sufficient power for effective operation. (The compressor is controlled by a low-pressure switch mounted on the Condensing Unit. This feature eliminates the need for wiring between the Evaporator Unit (Fan Coil Unit) and the Condensing Unit).

- Ensure the voltage supplied matches the rating specified on the unit spec. label.
- Provide a non GFI dedicated circuit and an appropriate outlet for the Evaporator Unit's (Fan Coil Unit) power cord.
- Provide a dedicated circuit and circuit breaker for the Condensing Unit.
- Provide a weatherproof disconnect for Condensing Units located outside.

As with all sensitive electrical equipment, damage may be caused in the event of power surges and spikes. WhisperKOOL recommends plugging the unit into a surge protector, or power conditioner, in order to protect your system. As outlined in our Terms & Conditions, power surges and spikes are not covered under warranty.

**WE RECOMMEND THAT YOU DO NOT USE A GROUND FAULT INTERRUPTER (GFI) WITH THIS PRODUCT.**

In case the system should lose power, check the home/main circuit breaker. If the system does not respond properly, refer to the Troubleshooting Guide on page 40.

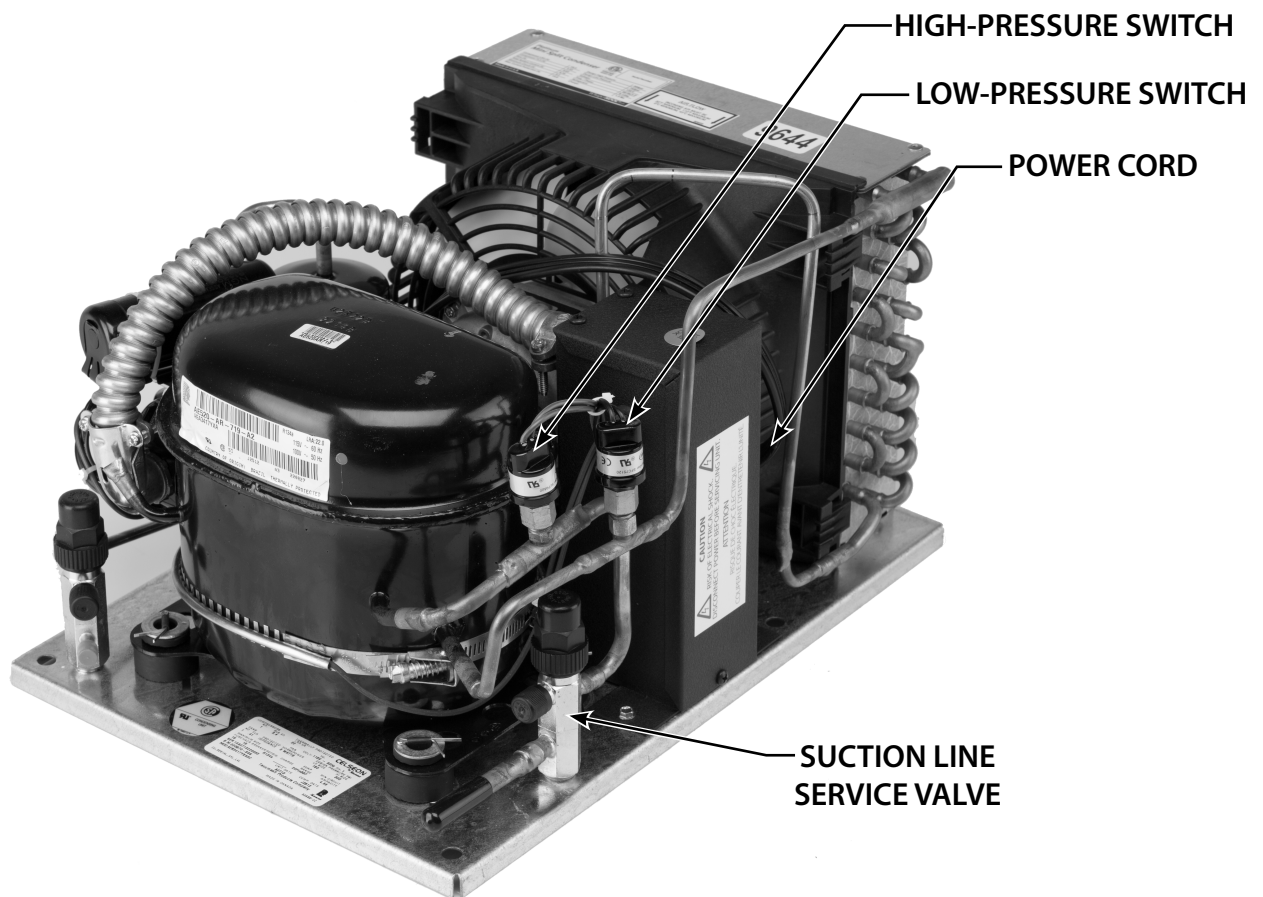

For the equipment warranty to be valid, WhisperKOOL requires that the installation is performed by a certified HVAC-R technician (NATE certified technician is recommended) per the specifications outlined in this Technician's Manual. The technician shall be required to be equipped with the proper tools of the trade including: R-134a, brazing equipment, dry nitrogen, an accurate manifold gauge set (digital preferred), plus a 4 valve manifold set for evacuation, digital micron gauge, digital scale, deep vacuum pump and accurate digital thermometers. Without the proper equipment, a professional job cannot be accomplished. Evidence of the certified tech's NATE# or other certification is required.

# MINI CEILING MOUNT CONDENSER WIRING DIAGRAM

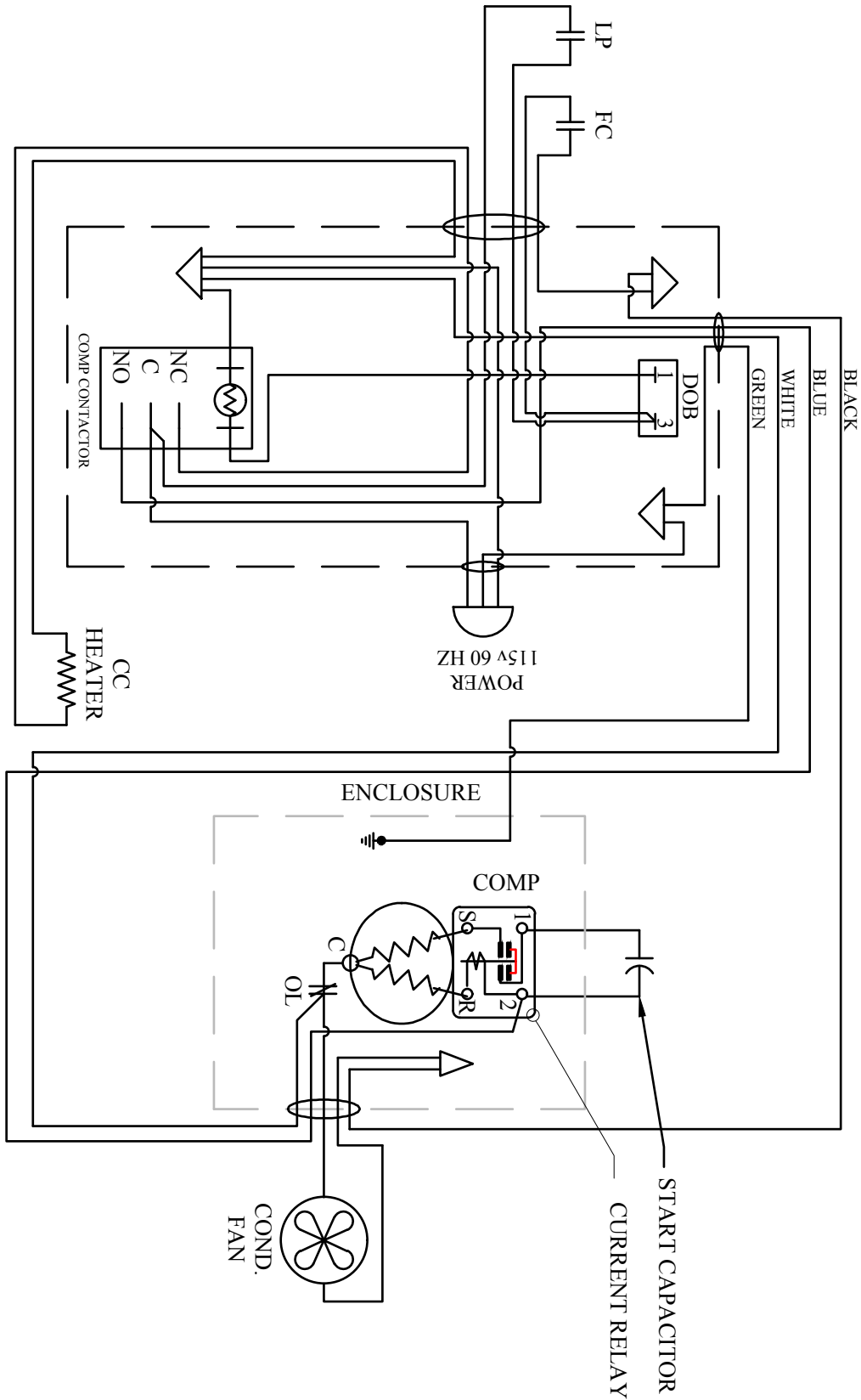

# MINI CEILING MOUNT CONDENSER WIRING DIAGRAM

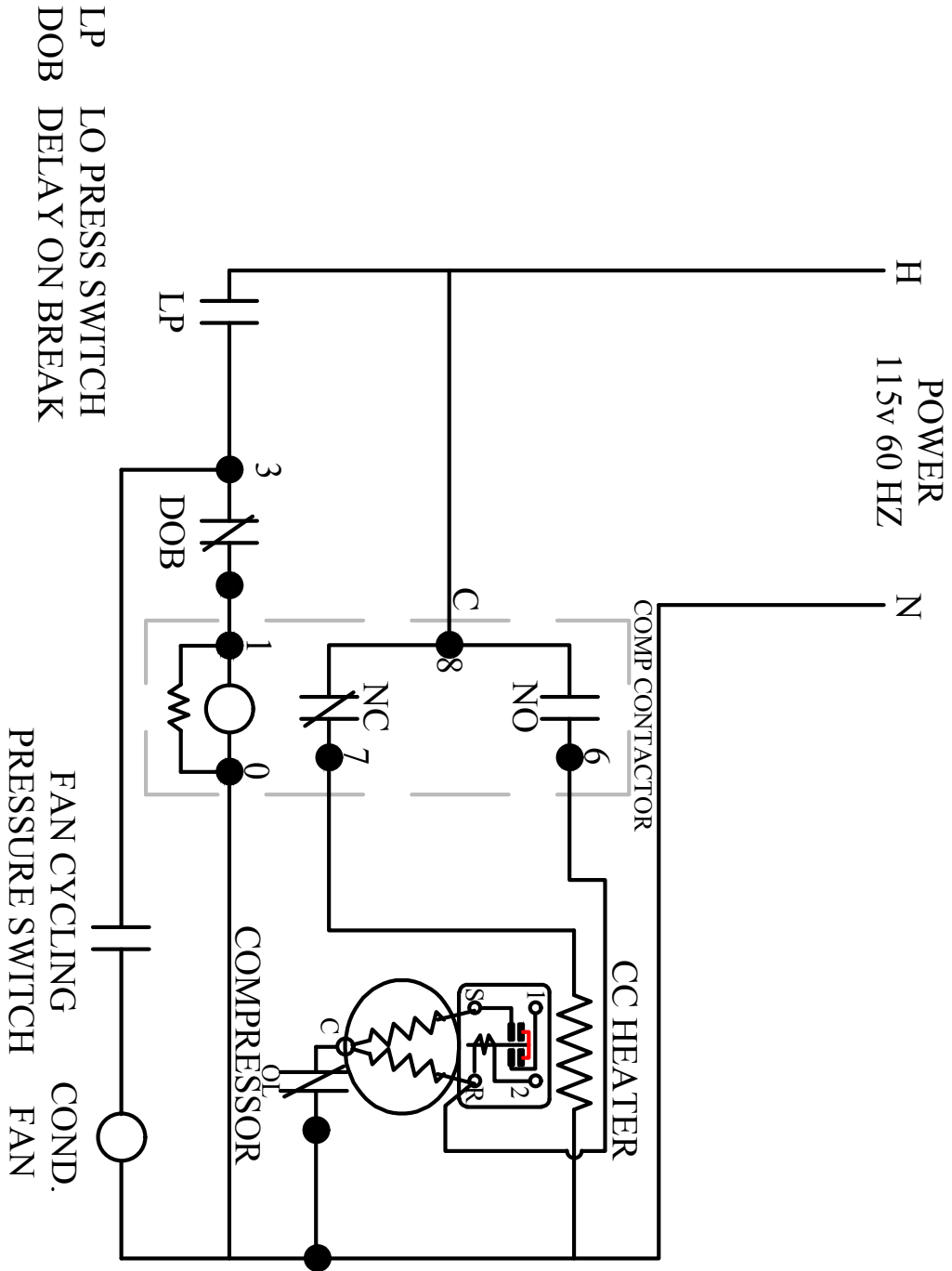



# PREPARING THE CONDENSING UNIT (continued)

## Installing the Condensing Unit

The Condensing Unit can be installed inside a well ventilated area of the home, but it is typically installed outside. Exterior applications will require the use of a protective housing, and the amount of sun exposure should be considered when selecting the placement of the Condensing Unit. The Condensing Unit requires a dedicated 20amp circuit, non-GFI. Make sure there is a minimum 3 ft. horizontal clearance in the front and rear of the unit. The unit should be plugged in.

Set the Condensing Unit level and with proper clearances in accordance with the instructions, name plate power supplied, proper electric disconnect, and fuse protection connected but not turned on and ready for piping connections.

### Inside Condensing Unit Installations:

Inside installations require special consideration, as there must be adequate ventilation to remove the heat created during normal operations. An exhaust port with fan may need to be installed to ensure that heat is effectively removed from the utility room. A return grille or provision for 500 - 600 cfm of cool air to enter the room to replace the exhausted air will accomplish this. Unobstructed airflow to and from the unit is a critical factor in the units overall performance. Make sure there is a minimum 3 ft. horizontal clearance in the front and rear of the Condensing Unit and at least 1 ft. on each side. This will assure that the unit can move the air around the room in an efficient manner.

### Outdoor Condensing Unit Installations:

You must utilize the exterior Condensing Unit housing for outdoor installations. Place the Condensing Unit on a solid foundation in a location with adequate ventilation. There should be 3 ft. of clearance in the front and rear of the unit and 1 ft. on each side. The unit should be elevated 18" in order to avoid any possible flooding or damage by animals, and should be clear of leaves, dirt, and other debris.

### Fan Cycling Switch:

These switches are used to cycle the condenser fan at low ambient temperature conditions.

### Refrigeration Lines:

A 1/4 inch O/D copper liquid line is required.

## Suction Line Size Chart

Model	Line Set Length	<25ft			26-50ft			50-100ft		
	Vertical Rise	<3ft	3-10ft	>10ft	<3ft	3-10ft	>10ft	<3ft	3-10ft	>10ft
Mini Ceiling Mount Split	Horizontal Tubing	3/8"								
	Vertical Rise	3/8"								

The refrigerant drier and the sight glass shall be installed (in that order) in the direction of the refrigerant flow in the liquid line between the Condensing Unit and Evaporator Unit (Fan Coil Unit). Enclose the suction line in a cellular insulation 1/2" wall thickness Armaflex (brand name) or equal to reduce heat transfer and prevent the suction line from sweating.

# LINE SET PIPING DIAGRAMS

These are 2 options for running the line set from the coil to the Condensing Unit. Option 1 is specifically for when the system is installed with the Condensing Unit below or leveled to the coil. Option 2 is for when the system is installed with the Condensing Unit at a higher elevation than the coil.

**SINGLE FAN COIL PIPING SYSTEM**  
 CONDITION: CONDENSING UNIT BELOW OR CLOSE TO SAME  
 ELEVATION AS FAN COIL UNITS

## Option 1

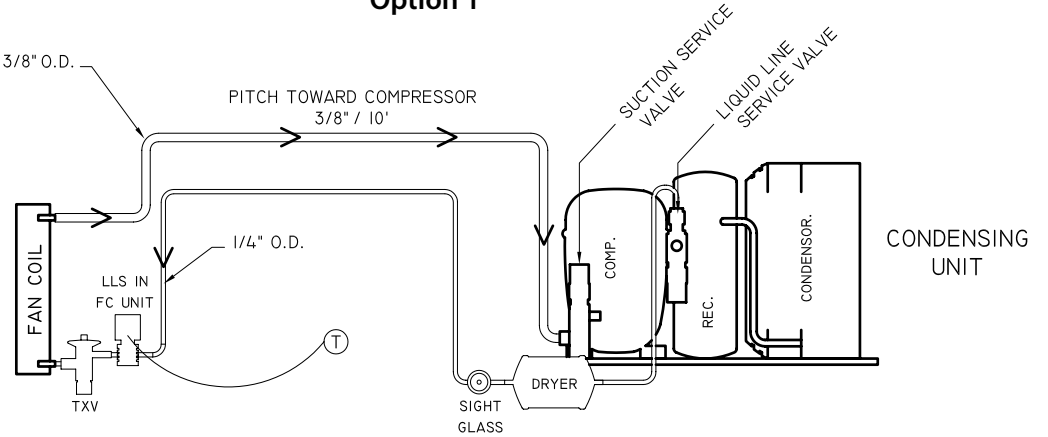

**SINGLE FAN COIL PIPING SYSTEM**  
 RECOMMENDED REFRIGERANT PIPING DESIGN FOR CONVENTIONAL FACTORY SUPPLIED FAN COIL AND AIR COOLED CONDENSING UNIT COMPONENTS. REFRIGERANT LINE LENGTHS IN EXCESS OF 90' NOT RECOMMENDED.

THIS DRAWING APPLIES TO CONDENSING UNIT LOCATION AT OR BELOW THE ELEVATION OF THE FAN COIL UNIT. SUCTION PIPE TO BE INSULATED WITH 1/2" WALL INSULATION (ARMAFLEX BRAND) OR EQUAL.

**SINGLE FAN COIL PIPING SYSTEM**  
 CONDITION: CONDENSING UNIT ABOVE FAN COILS AND  
 VERTICAL PIPES HAVE GREATER THAN 3' RISE.

## Option 2

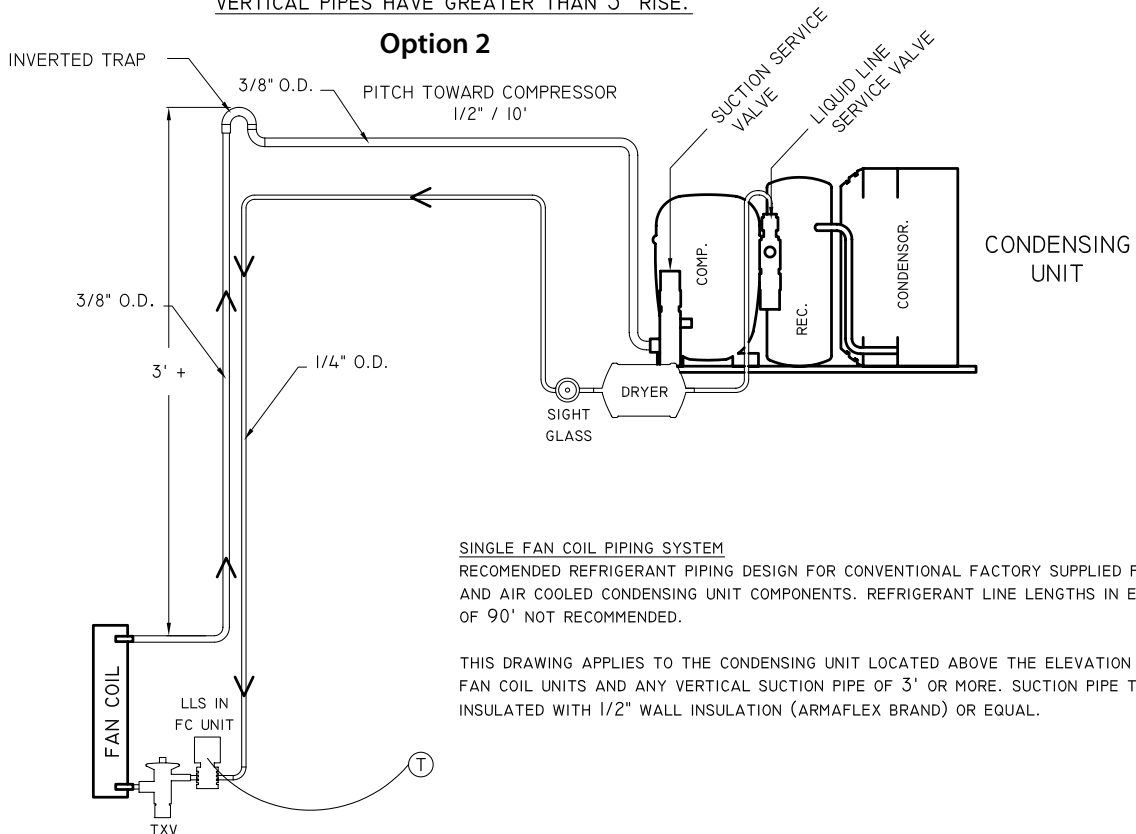

**SINGLE FAN COIL PIPING SYSTEM**  
 RECOMMENDED REFRIGERANT PIPING DESIGN FOR CONVENTIONAL FACTORY SUPPLIED FAN COIL AND AIR COOLED CONDENSING UNIT COMPONENTS. REFRIGERANT LINE LENGTHS IN EXCESS OF 90' NOT RECOMMENDED.

THIS DRAWING APPLIES TO THE CONDENSING UNIT LOCATED ABOVE THE ELEVATION OF THE FAN COIL UNITS AND ANY VERTICAL SUCTION PIPE OF 3' OR MORE. SUCTION PIPE TO BE INSULATED WITH 1/2" WALL INSULATION (ARMAFLEX BRAND) OR EQUAL.

# INSTALLING THE CONDENSING UNIT

## Refrigerant Piping Procedure

When installing/routing the line set, cap both ends of each tube to prevent material or debris from entering the tubing.

Prior to connecting the piping, loosely connect the refrigerant gauges to the service ports of the suction and liquid line service valves. Purge the charging hoses with dry nitrogen and tighten the hose connections. Remove the service valve caps and turn the valve stem clockwise (half of a complete turn) in order to unseat the valve and open the service port. The valve comes in a back seated position from the factory. Keep the piping port sealed until ready to connect to the vacuum pump.

Cleanliness is of the utmost importance. All horizontal suction piping should be pitched toward the Condensing Unit 1/2" for every 10' of pipe. During any brazing procedure, dry nitrogen should be purged through the fitting at a slow rate to prevent formation of highly abrasive copper oxide. Make sure there are no obstructions to the flow which would cause pressure build up and the brazed fittings to leak. After leak testing and confirming there are no leaks, insulate suction line with 1/2" wall thickness Armaflex or equal insulation. Seal all seams using Armaflex 520 Foam Insulation Adhesive or equivalent. Wrap each seam using line set tape.

## Liquid Line Piping Procedure

It is required to use a 1/4" OD copper tube liquid line. When making connections keep the ends sealed until ready to fit the tube. First connect the supplied refrigerant drier close to the liquid service valve (king valve) on the receiver. Downstream, connect the moisture indicating sight glass in an easily visible location. Run the tubing to the Evaporator Unit (Fan Coil Unit) location and fit to the liquid line stub from the Evaporator Unit (Fan Coil Unit). Energize the Evaporator Unit (Fan Coil Unit) and set the temperature controller to call for cooling. This will activate the liquid line solenoid valve. Uncap the suction pipe to prevent obstructed nitrogen flow. Open the nitrogen to allow a slow flow and braze the liquid line fitting. Do not shut off the nitrogen and power until the suction line is brazed.

## Suction Piping Procedure

Slide Aramaflex insulation over the tubing for the entire length of the tube and keep the end of the tube sealed during this procedure. Keep the tubing sealed while running the connection points and fit the suction tube to the Evaporator Unit (Fan Coil Unit) outlet connection. Install a Schrader Type Access Valve at the outlet of the Evaporator Unit (Fan Coil Unit) to allow for superheat checking. If there are brazed fittings along the length of the tube, apply the insulation after leak testing.

## After All Piping Ran and Ready for the Brazing Process

Energize the Evaporator Unit (Fan Coil Unit) and set the temperature controller to call for cooling. Open the liquid line service valve and bleed the nitrogen through both the liquid and suction line. Loosen the suction gauge hose to relieve pressure during the brazing process. Braze the connections and cool them off quickly.

## Leak Testing

Using dry nitrogen, pressurize the system to 200 psi. Check to see if there is a noticeable pressure drop. If so, locate and fix leak. With pressure at 200 psi, check for leaks with a refrigerant leak detector and/or soap bubbles. Confirm the pressure holds at 200 psi for 30 minutes. If not, check again for leaks and repair, then perform another leak test. When it is confirmed that there are no leaks, release the nitrogen pressure and leave the solenoid valve energized.

# INSTALLING THE CONDENSING UNIT

## Evacuation

Connect the evacuation type 4 valve gauge manifold to high and low-pressure service valve ports on the Condensing Unit with the valve stems mid-seated as when leak testing. Install service caps on the valves and tighten them. Energize the liquid line solenoid valve (make sure there is fresh oil in the vacuum pump). Connect a micron gauge directly to the pump, blank off, and start the pump to verify that it is capable of 200 micron vacuum and the gauge is capable of reading that vacuum. Connect the micron gauge to the access valve installed in the suction line at the evaporator. Remove the Schrader Valve Depressors from the gauge hoses to reduce restriction and connect gauges to the suction and liquid line service valve service ports on the Condensing Unit. Connect the pump to the 3/8" hose on the manifold set. Start the pump and run until the micron gauge reads 200 microns.

When a 200 micron level evacuation is achieved, break the vacuum with R-134a and add enough refrigerant to pressurize the system with a few psi of positive pressure.

## Charging

Remove the vacuum pump and the micron gauge. Install a spare low-pressure gauge to the access valve at the evaporator. With the power off to the Condensing Unit, place the cylinder of R-134a on a digital scale. Admit liquid refrigerant to the system through the high-pressure side (liquid line service valve) until the refrigerant stops flowing or until about 3 lbs have been added. Shut off refrigerant flow to system.

Fill a wine bottle  $\frac{3}{4}$  full with water between 60-75°F. Insert the bottle probe into the neck of the bottle as far as possible. (It is important the bottle probe stopper is compressed by the neck of the bottle to ensure water will not leak out). Verify that the bottle probe is properly installed and the set point on the controller is low enough to allow the system to run continuously for 30 minutes or more. Turn on power to the Condensing Unit and the compressor should start if suction pressure is above 20 psi. If the system pumps down and the compressor shuts off, set the 5 minute time delay relay time to the lowest setting to avoid having to wait. Add refrigerant as a vapor through the low-pressure side of the system (suction service valve port).

Observe the sight glass when the compressor starts. If bubbles are present, slowly add more refrigerant in vapor form to the low side. The suction pressure and head pressure should increase as the sight glass clears. Check the superheat during the charging process. If the superheat drops to 4-5°F and sight glass still has bubbles, let the unit run until the wine cellar temperature drops and approaches 55°F. Observe the sight glass. If bubbles are present, add additional refrigerant in small increments. Let the system stabilize for about 5 minutes and check the sight glass for bubbles before adding additional refrigerant. Once the sight glass is clear, check the superheat at the outlet of the evaporator (evaporator superheat should be between 8-12°F). If superheat is not between 8-12°F, make an adjustment to the expansion valve. Depending on the temperature, the high side should be approximately 175 lbs, and the low side should be 28 lbs or more to keep the evaporator from icing.

## Measure Superheat

If superheat is high and bubbles are present, add more refrigerant until it is clear. If superheat is low (around 4-6°F) and bubbles are present in the sight glass, check for liquid refrigerant entering the compressor as evidenced by cool crankcase below 100-110°F and low discharge superheat. Adjust TXV setting in small increments to increase superheat and stop liquid from going to the compressor. Check this before adding more refrigerant. If the temperature of the air entering the condenser is cold enough to cause the condenser fan to cycle, block about 60% of the coil to raise the head pressure and allow time for stabilization. Reduce blockage if the condensing temp is above 115°F Fahrenheit. Retain blockage if necessary to maintain stability for performance test listed in the Split System Warranty Checklist. If the air is cold, below 60°F entering the condenser and the sight glass is clear; allow the system to run for a while until the cellar cools off, then measure and record data on the Split System Warranty Checklist.

Confirm the controller is displaying the correct temperature and that the controller is not displaying an alarm. If the controller is displaying an alarm, reference page 37 for corrective action. Confirm that the suction line is completely insulated, from TXV to compressor. Confirm that the sight glass has no bubbles and the ambient temperature around the Condensing Unit is not getting excessively hotter. Confirm that both king valves have been back seated and the nuts have been installed back on the king service ports.

**Insulate the 3/8" suction line with cork tape.**

# SYSTEM OPERATION

## Initial Start-Up

When power is applied to the unit, the control will briefly display all symbols, and the Snowflake symbol will be displayed (if unit is calling for cooling). There may be a brief (up to 60 sec.) delay prior to the evaporator fan turning on. When the evaporator fan is activated the Fan symbol will display.

APST (Advance Product Safety Technology) is a temperature control feature for the evaporator fan that comes standard with all WhisperKOOL units. APST ensures that in the possible event of a cooling deficiency, the heat from the indoor fan will not raise the temperature of the wine cellar, which could otherwise have an adverse effect on the wine-aging process.

## Set Point

The set point is set from the factory (WhisperKool) at 55F°. It can be adjusted by the customer between 45–67F° in one degree increments.

## Humidity Features

The FON function is an adjustable feature which allows the customer the convenience of reintroducing some of the humidity removed by the fan coil during the cooling process. The FON Function controls the evaporator fan operation once the set point has been reached. When the bottle probe has reached the set point (all units are shipped with the set point of 55°F and a differential of 1°), the compressor and the condenser fan will turn off, but the indoor fan will continue to run for about 5 minutes to re-introduce any moisture from the evaporator coil. All units come with this feature turned off. If low humidity is a problem an increase in this setting will raise the humidity level. The FON function is one of the many Customer Preference Selection features that allow the customer the ability to fine-tune the controls.

The Fon parameter can be increased to allow the evaporator and condenser fans to run for a longer period of time after the compressor turns off, allowing more moisture to be re-introduced into the wine cellar.

## Anti-Short Cycle

The Anti-Short Cycle ensures that the unit will remain off for a period of five minutes after the unit has reached the set point to allow the pressure in the refrigeration system to equalize prior to starting the compressor.

## Anti-Frost Cycle (defrost)

The system will go through an Anti-Frost cycle every 4 hours. This will shut down the compressor and allow the evaporator and condenser fans to run to evaporate any frost accumulation on the coil. The compressor will remain off until the evaporator coil reaches 40F°, or for a maximum of ten minutes. The unit will then return to normal operation.

## Low Ambient Conditions

If the condensing unit is installed outdoors (which allows the condenser to be exposed to low ambient temperatures), the condenser fan may cycle on and off. The purpose of the fan cycling is to maintain the system high side pressure, which will ensure an adequate refrigeration process. The fan cycling process is accomplished by way of a Johnson Control or fan cycling switch attached to the condensing unit.

## Bottle Probe Failure Protection

In the event that a bottle probe should fail, the APST (Advance Product Safety Technology) will automatically transition the refrigeration compressor cycles to a pre-determined time series (based on detailed laboratory testing), which will ensure that the product is kept within the safe range.

## Display

The bottle probe temperature is displayed by default. "Def" is displayed during Anti-Frost. The air sensing probe and evaporator probe temperatures can be accessed by pushing the SET button and scrolling through "PB1" (bottle probe), and "PB2" (evaporator probe).

## Safety Features

Once the cellar has reached the proper Set temperature, the compressor goes into its pump down cycle. When the compressor turns off the delay on break timer prevents the compressor from short cycling.

In the event of a faulty bottle probe, the compressor will cycle off for 10 minutes and on for 40 minutes. "E1" will be displayed on the screen.

## Alarms

See "Alarm Codes" in Controller Function chart.





## Remote Control Panel (standard)

The remote keypad is designed to give the user the ability to monitor and change cellar conditions when the evaporating unit is placed in a remote location outside of the cellar.

# CONTROLLER FUNCTIONS



## TEMPERATURE

Button	Normal Functions
<p><b>ON/OFF</b></p> 	<ul style="list-style-type: none"> <li>The ON/OFF button allows the customer the convenience of turning the refrigeration system ON or OFF from the control panel. This feature does not disconnect power from the unit. In order for the power to be shut off from the unit, the power cord must be unplugged from the wall receptacle.</li> <li>Press the ON/OFF button once for button application.</li> </ul>
<p><b>Up and Down Arrows</b></p>  	<ul style="list-style-type: none"> <li>Use these buttons to scroll up or down the CPSM (Customer Preference Selection Mode) menu.</li> <li>Displays the highest and lowest temperature sensed by the bottle probe. This feature allows the customer instant access to the recorded data applicable to the bottle probe Temperatures. It can be easily reset to reflect current temperatures.</li> </ul> <ol style="list-style-type: none"> <li>Press the "UP" arrow, or the "DOWN" arrow once, and the highest or lowest temperature (Hi/Lo) sensed by the bottle probe will be displayed.</li> <li>To reset the Hi/Lo, press and hold the "Set" button when the Hi/Lo value is displayed on the Digital Display, continue to hold the "Set" button until "rst" appears on the digital display and then blinks. This will erase the past-recorded "Temperature Data History" and start recording from the current time and temperature forward. Temperatures displayed would reflect bottle probe temperatures from that point in time and beyond.</li> <li>The Hi/Lo feature should be reset at initial "Start-Up" and after the cellar has obtained normal operating temperatures, which is generally 55°F.</li> </ol>
<p><b>Cellar PreChill (CPC)</b></p>  	<p>The CPC feature is activated by pressing the "UP" arrow for 3-5 seconds, and the CPC logo will be displayed on the digital display. The CPC feature can be terminated by pressing the "UP" arrow for 3-5 seconds, or the feature will self terminate after 6 hrs.</p> <ol style="list-style-type: none"> <li>The CPC feature may be used to Pre-Chill the cellar prior to loading it with warm product. The feature will shift the Set Point down to a lower setting of 52°F for the next 6 hours. After the 6 hour time period the set point will automatically return to the original Set Point.</li> <li>The CPC feature can be conveniently adjusted to the customer's specific needs by accessing the "Customer Preference Select Mode" (CPSM). See Customer Preference Select Mode Instructions.</li> </ol>

<b>SET</b>	<p><b>Set</b></p> <ol style="list-style-type: none"> <li>1. Press the “Set” button once and it will display the set point. After approximately 5 seconds, the display will return to normal operation and display the bottle probe temperature.</li> <li>2. Press the “Set” button once and it will display the set point. Press the “UP” and “DOWN” arrows to change the set point. Press the “Set” button again and the numbers will blink, confirming the change in set point.</li> <li>3. Press and hold the “Set” button during the display of the Hi/Low “Temperature Data History” (hold button unit “rst” blinks on display), and it will erase the past recorded data file and start recording from the current time and temperature.</li> <li>4. Press the “Set” and the “DOWN” buttons simultaneously, for <b>3-5 seconds</b>, and you will access the “Customer Preference Selection Mode” (CPSM). The CPSM allows the customer to fine-tune the Control Operating System to their applicable choice.</li> </ol>
	<p><b>Alarm</b></p> <p>The Alarm symbol is shown when the unit encounters an issue that needs attention. The displayed alarm codes are explained below.</p>

### Alarm Codes

Message	Cause	Solution
“P1”	<b>Bottle probe is unplugged</b>	<b>Attach bottle probe to unit</b>
	<b>Faulty bottle probe connection</b>	<ol style="list-style-type: none"> <li>1. <b>Check bottle probe attachment at circular connector.</b></li> <li>2. <b>Check bottle probe connection at green terminal block on the controller</b></li> </ol>
	<b>Defective bottle probe</b>	<b>Replace the bottle probe</b>
“P2”	<b>Faulty evaporator probe connection</b>	<b>Check evaporator probe connection at green terminal block on the controller</b>
	<b>Defective evaporator probe</b>	<b>Replace the evaporator probe</b>
“HA”	<b>Defective bottle probe</b>	<b>Replace the bottle probe</b>
“LA”	<b>The bottle probe is sensing a temperature of 4° below the set point</b>	<b>Allow the room to warm up. This will increase the temperature of the wine</b>
	<b>Defective bottle probe</b>	<b>Replace the bottle probe</b>
“POF”	<b>The keypad is locked</b>	<b>Hold “UP” and “DOWN” arrows for 3 to 5 seconds to disable, “PON” should appear</b>
“BAL”	<b>Unit is not draining properly</b>	<ol style="list-style-type: none"> <li>1. <b>Check the drain line for kinks or obstructions</b></li> <li>2. <b>Check the Condensate Pump for proper operation</b></li> </ol>

<p><b>CPSM Mode</b></p>	<p>Press the "Set" and the "DOWN" buttons simultaneously, for <b>3-5 seconds</b> and you will access the "Customer Preference Selection Mode" (CPSM). The CPSM allows the customer to "Fine Tune" the Control Operating System to their applicable choice.</p> <p>The following CPSM options are available for adjustment:</p> <p>Fon – Humidity Management Enhancement: This parameter is normally set at 0, which should provide adequate relative humidity for the cellar.</p> <ul style="list-style-type: none"> <li>• An increase in this parameter will increase the Humidity Enhancement (%RH), and a decrease in the parameter will decrease Humidity Enhancement (%RH).</li> <li>• Adjustments should be made in increments of 5, with a maximum of 15, and a minimum of 0.</li> <li>• After any adjustment to Humidity Enhancement, <b>you should wait a minimum of three days</b> before making any additional adjustments. This will allow the cellar sufficient time to acclimate to the new setting.</li> </ul> <p>Fof - Humidity Management Enhancement: This parameter is normally set at 15. <b>This parameter should not be adjusted</b>, as it simply provides an OFF cycle time for the fan during the compressor OFF cycle. However, the parameter is located within the CPSM as a convenience to the customer, should it need to be adjusted. CCT - Cellar Pre-Chill Duration: This parameter is set to 6 hours, but can be changed between 0-23.5 hours.</p> <p>Con/Cof – Compressor On time (Con) and Off time (Cof) with a Probe 1 failure/Alarm. These parameters are set at Con 40 min/Cof 10 min. In the event that there is a Probe 1 failure/ Alarm, the compressor/refrigeration system automatically starts a predetermined ON/OFF cycle, which is controlled by the Con and the Cof parameters. The customer can adjust these parameters to maintain the desired bottle temperature.</p>
-------------------------	---



# MAINTENANCE SCHEDULE

<b>Monthly</b>	<ol style="list-style-type: none"><li>1. Check for debris surrounding condensing unit(i.e. leaves, branches, trash ect.). Remove all obstructions.</li><li>2. Check for unusual noise or vibration.</li><li>3. Check the drain line to see if it is above the waterline if draining into a vessel.</li></ol>
<b>Quarterly</b>	<ol style="list-style-type: none"><li>1. Use a vacuum with brush attachment to clean the evaporator coil. Be careful not to crush coil fins when cleaning.</li><li>2. Ensure the condensing unit is free of debris and dust.</li><li>3. Have a certified HVAC Technician service the condensing unit/clean the condenser coil.</li><li>4. Check condensate pan for sludge build up and dirty filter in the pump's reservoir. A condensate drain pan treatment is highly recommended to prevent scale and sludge build up.</li></ol>
<b>Annually</b>	<ol style="list-style-type: none"><li>1. Inspect for corrosion.</li><li>2. Check wiring connections and integrity of cords.</li><li>3. Pour a 50/50 bleach solution into the drain line every spring.</li></ol>

# TROUBLESHOOTING GUIDE

## Unit has ice forming on the evaporator

Possible Cause	Solution
There is something blocking the supply and or return air.	Remove blockage.
The evaporator fan is not turning on.	Call a service tech to troubleshoot.
The evaporator unit has not gone through its anti-frost sequence yet.	Check for ice in the depth of the coil. Melt with blow drier until coil is warm to the touch. Soak up water with a towel.
If evaporator unit continues to ice.	Observe ice formation pattern. If only part way up the coil face, the system could be low on refrigerant. If all the way up, the coil may be dirty or airflow is blocked.

## Unit does not run/power up

Possible Cause	Solution
Evaporator unit is not plugged in.	Make sure the unit is plugged into an outlet.
Power switch not on.	Turn unit on by pressing the power button on the control.
Line voltage is incorrect rating for the system.	Check line voltage to make sure there is 110v/120v.
Bottle at set point.	Lower set point.
Thermostat not calling for cooling.	Lower set point.
Faulty thermostat or wiring.	Call Customer Service at 1-800-343-9463

## Cellar temperature is to warm

Possible Cause	Solution
The temperature of the room condensing unit is exhausting and has exceeded 110°F	Intake temperature needs to drop below 85°.
The system is undersized for the cellar.	Order correct size system.
There is something blocking the supply and/or return air on evaporator or condenser side of the unit.	Remove air flow obstruction.
Compressor is not turning on.	Please contact the installing technician to troubleshoot.
Compressor keeps cycling on overload.	Make sure condenser fan is working and no airflow obstruction.
Poor seal around door or other areas requiring a seal (around the unit, wall joints, etc.).	Make sure there are no air gaps around the door. If door seal is damaged, replace it.
Controller set too high.	Lower the set point.
Evaporator coil is frosted or iced up.	Observe ice formation pattern. If only part way up the coil face, evaporator unit could be low on refrigerant. If so, contact your
	installing technician to assist with troubleshooting.

## System runs constantly

Possible Cause	Solution
Leaky door seal or poorly insulated cellar.	Fix leaky door seal and insulate cellar in accordance with this manual. (Page 9)

# TROUBLESHOOTING GUIDE

<b>Unit leaks water</b>	
<b>Possible Cause</b>	<b>Solution</b>
Evaporator unit is not level.	Evaporator unit should be level in ceiling to prevent leaking.
Drain line clogged or kinked.	Check drain line to make sure water can flow freely.
Drain is clogged preventing water from escaping.	Disconnect drain and clear out, check drain for blockage.
Drain line does not have a downward slope.	Fix drain line so there is a downward slope from the unit to the drain.
Coil is iced causing drain pan ice and water overflowing.	Melt ice with blow drier. Soak up with a towel.
<b>Unit runs but does not cool</b>	
<b>Possible Cause</b>	<b>Solution</b>
Lack of air flow.	Make sure fan is unobstructed; evaporator coil, and condenser coil are clean and free of debris.
System undersized.	Call Customer Service at 1-800-343-9463
Compressor is overheating.	Shut system off for 1 hour to allow compressor to cool. Turn back on and check for cooler airflow out. If compressor runs, check for and clean condenser coil as possible cause of compressor overheating. If problem repeats, contact your installing technician to assist with troubleshooting.
<b>Evaporator fan runs but compressor does not</b>	
<b>Possible Cause</b>	<b>Solution</b>
Running an anti-frost cycle.	1) If the system is maintaining the correct cellar temperature and there is a dripping snowflake symbol illuminated on the control, the system is going through an anti-frost cycle. No action Required. 2) If the system is not maintaining the correct cellar temperature, this may be caused by a dirty evaporator coil. 3) Call installing technician to troubleshoot, as the system may be low on charge or an adjustment to the TXV.
Compressor and/or starting components faulty.	Please contact the installing technician to troubleshoot.
System may be performing the WHM function.	Allow cooling system to revert back to cooling mode.
Compressor may have overheated.	Shut system off for 1 hour to allow compressor to cool. Turn back on and check for cooler airflow out. If compressor runs, check for and clean condenser coil as possible cause of compressor overheating. If problem repeats, contact your installing technician to assist with troubleshooting.
<b>Compressor runs but evaporator fan does not</b>	
<b>Possible Cause</b>	<b>Solution</b>
Faulty fan motor.	Please contact the installing technician to troubleshoot.
Faulty controller.	Please contact the installing technician to troubleshoot.
<b>Compressor short cycles</b>	
<b>Possible Cause</b>	<b>Solution</b>
Evaporator blows on bottle probe.	Move bottle probe to a more central location.
System low on refrigerant charge.	Please contact the installing technician to troubleshoot.
Condensing fan motor/capacitor faulty.	Please contact the installing technician to troubleshoot.
Compressor and/or starting components faulty.	Please contact the installing technician to troubleshoot.
<b>Humidity in cellar too low</b>	
<b>Possible Cause</b>	<b>Solution</b>
Not enough moisture.	Raise the Fon setting to increase the humidity level.

# TECHNICAL ASSISTANCE

WhisperKOOL Customer Service is available Monday through Friday from 6:00 a.m. to 4:00 p.m. Pacific Standard Time.

The appointed customer service representative will be able to assist you with your questions and warranty information more effectively if you provide them with the following:

- The model and serial number of your WhisperKOOL systems.
- Location of unit and installation details, such as ventilation, ducting, construction of your wine cellar, and room size. Photos of the cellar and installation location may be needed.

## Contact WhisperKOOL Customer Service

1738 E. Alpine Ave  
Stockton, CA 95205  
[www.WhisperKOOL.com](http://www.WhisperKOOL.com)  
E-mail: [support@whisperkool.com](mailto:support@whisperkool.com)  
Phone: 209-466-9463  
US Toll Free: 1-800-343-9463  
Fax: 209-466-4606

# ACCESSORIES FOR COOLING UNITS

**WhisperKOOL offers accessories to enhance and customize your wine-cooling unit.**

## Exterior Housing

Protects the condensing unit from the weather elements when the unit is located outside.

**Accessories can be purchased at [www.whisperkool.com](http://www.whisperkool.com)**

**WhisperKOOL Product Terms and Conditions**  
**Including Product Limited Warranty And Product Installation Requirements**  
**For WhisperKOOL Split System Series**

ATTENTION: PLEASE READ THESE TERMS OF USE CAREFULLY BEFORE INSTALLING YOUR WHISPERKOOL COOLING SYSTEM. INSTALLING YOUR WHISPERKOOL COOLING SYSTEM INDICATES THAT YOU ACCEPT AND AGREE TO EACH OF THE TERMS AND CONDITIONS SET FORTH HEREIN ("TERMS OF USE"). IF YOU DO NOT ACCEPT THESE TERMS OF USE, YOU RISK VOIDING YOUR WARRANTY AND ASSUMING ADDITIONAL REPAIR AND REPLACEMENT COSTS.

**1. Purchase of a WhisperKOOL Cooling System assumes that the Purchaser ("End User") fully accepts and agrees to the Terms and Conditions set forth in this document. The Terms and Conditions of Sale and Owner's Manual are shipped with each unit and, if another copy is needed, replacement copies can be downloaded from the company website ([whisperkool.com](http://whisperkool.com)) or by contacting WhisperKOOL directly for a new copy. WhisperKOOL reserves the right, in its sole discretion, to change its Terms and Conditions at any time, for any reason, without notice.**

**2. WhisperKOOL Product Installation and Limited Warranty**

- A. Purchaser of the product must arrange for the product to be installed by a certified HVAC/R technician in accordance with procedures set forth by WhisperKOOL and described in the WhisperKOOL Owner's Manual.
- B. The HVAC/R technician installing the product must complete the designated portion of the Split Startup Checklist and provide licensing or certification identification number information to assist in the warranty registration process.
- C. Purchaser must return the completed Split Startup Checklist to WhisperKOOL within thirty (30) days of installation of Product. The Split Startup Checklist must be approved by WhisperKOOL to activate the Limited Warranty. If the Split Startup Checklist is approved, Purchaser will be sent activation approval documents and will start receiving the benefits of the Limited Warranty throughout the warranty period. If the Split Startup Checklist is incomplete, Purchaser will be informed they have five days to complete the Split Startup Checklist and re-submit to WhisperKOOL. The Split Startup Checklist will be reviewed again, and if denied, Purchaser will be informed that they have 10 business days for corrective action. Failure to register the Product may result in loss of warranty.
- D. Purchaser is responsible for the full costs of installation and any additional parts required for the proper and complete installation of the product.
- E. For Split Systems returned to WhisperKOOL in accordance with the terms and conditions of the Limited Warranty, WhisperKOOL warrants against defects in material and workmanship as follows:
  1. **LABOR** — For a period of two (2) years commencing on the date of purchase, WhisperKOOL will, at its option and discretion, reimburse up to \$250 to the End User for cost incurred for servicing, repairing, removing or installing warranty parts. Invoice for service must be forwarded to WhisperKOOL for assessment and processing. The Split System warranty is invalid if there is attempted repair by anyone other than an HVAC/R technician approved by WhisperKOOL to service the Product.
  2. **PARTS** — For a period of two (2) years commencing on the date of purchase, WhisperKOOL will supply, at no charge, new or rebuilt replacement parts in exchange for defective parts. Replacement parts are warranted only for the remainder of the original warranty period.
  3. **FREIGHT** — For a period of two (2) years commencing on the date of purchase, if after WhisperKOOL approved evaluation the original Product failure is determined to be the cause of a manufacturers defect, and not the cause of an installation error or other cause, WhisperKOOL will cover at its option, freight for the replacement parts or Product.

**The following part or cause of failure is not the responsibility of WhisperKOOL:**

- Improper voltage supply
- Line set with screw connectors (high end and low end)
- Leaks found at the braze points when performing pressure check
- Unit that has been charged incorrectly

- Incorrect tubing diameter used on line set
- A unit that has been wired incorrectly
- Valve stem on condenser side
- Improper installation of P-Trap
- Lack of P-Trap (if required)
- Condensers that are installed outdoors or in elements that would affect operation without proper cover or housing. (Housing is available from Manufacturer).

**Product Warranty Limitations and Exclusions.**

1. This limited warranty does not cover cosmetic damage caused during installation, damage due to acts of God, commercial use, accident, misuse, abuse, negligence, or modification to any part of the Product. Delivery and installation of the Product, any additional parts required, as well as removal of the Product if warranty work is required, are all at the sole cost, risk and obligation of the End User.
2. This limited warranty does not cover damage due to improper installation or operation or lack of proper maintenance of the Product, connection of the Product to improper voltage supply, or attempted repair of the Product by anyone other than a technician approved by WhisperKOOL to service the Product.
3. This limited warranty does not cover any Product sold "AS IS" or "WITH ALL FAULTS."
4. Product that has been replaced during warranty period does not extend the warranty period past the original date of purchase.
5. This limited warranty is valid only in the continental United States. Sales elsewhere are excluded from this warranty.
6. Proof of purchase of the Product in the form of a bill of sale, receipted invoice or serial number, which is evidence that the Product is within the Limited Warranty Period, must be presented by the End User to WhisperKOOL in order to obtain limited warranty service.
7. This limited warranty is void if the factory applied serial number has been altered or removed from the Product.
8. This limited warranty is voided if installed in an enclosure of insufficient design that does not follow the Product installation requirements stated herein and in the owner's manual.
9. Removing the rivets from the Product's unit housing without prior authorization from WhisperKOOL voids this limited warranty.
10. The End User must first contact WhisperKOOL Customer Service by telephone (at 1-800-343-9463) prior to attempting service on any Product still under the limited warranty; else the limited warranty is voided.
11. This limited warranty does not cover Product being concealed by, but not limited to, vegetation, fabric, shelving, mud, snow, or dirt. Product must not be painted or limited warranty will be void.
12. This limited warranty does not cover exposure to corroding environments such as, but not limited to, petroleum and gasoline products, cleaning solvents, caustic pool chemicals, and marine air.
13. This limited warranty does not cover any cause not relating to Product defect.
14. THE REPAIR OR REPLACEMENT OF THE PRODUCT AS PROVIDED UNDER THIS LIMITED WARRANTY IS THE EXCLUSIVE REMEDY OF YOU, THE END USER, AS WELL AS ANYONE ELSE IN THE CHAIN OF TITLE OF THE PRODUCT, DOES NOT START A NEW LIMITED WARRANTY TIME PERIOD, AND IS IN LIEU OF ALL OTHER WARRANTIES (EXPRESS OR IMPLIED) WITH REGARD TO THE PRODUCT. IN NO EVENT SHALL WHISPERKOOL BE LIABLE FOR INCIDENTAL, CONSEQUENTIAL, SPECIAL OR CONTINGENT DAMAGES FOR BREACH OF ANY EXPRESS OR IMPLIED WARRANTY ON THIS PRODUCT. THE IMPLIED WARRANTIES OF MERCHANTABILITY
15. AND FITNESS FOR A PARTICULAR PURPOSE ARE HEREBY EXPRESSLY DISCLAIMED. Some states do not allow the exclusion or limitation of incidental or consequential damages, or allow limitations on how long an implied warranty lasts, so the above limitations or exclusions may not apply to you. This limited warranty gives you specific legal rights, and you may have other rights, which vary from state to state.
16. Failure of the End User to comply with all of the Product Installation Requirements, Maintenance Requirements and End User Requirements may, at WhisperKOOL's sole discretion, void this limited warranty.
17. No one has any authority to add to or vary the limited warranty on this Product.

### 3. Maintenance Requirements

The End User is responsible for checking the coils on the condenser unit and vacuuming them every three months to maintain them free of debris. It is the End User's responsibility to clean off any accumulated dust, lint, or other debris from the front and rear intake grills; failure to do this on a regular basis will restrict the airflow and may affect the Product's ability to function properly. Periodically cleaning the Product's vents will help assure maximum cooling efficiency. The drain tube must also be checked and kept clean and free of debris and mold to maintain proper performance.

Mold is a natural living organism in the environment. It exists in the air in the form of microscopic spores that move in and out of buildings through doors, windows, vents, HVAC systems and anywhere else that air enters. Once it is discovered, mold must be addressed quickly and appropriately. Delayed or improper treatment of mold issues can result in costly and reoccurring repairs. If the End User suspects a mold problem, it is always best to hire a qualified and experienced mold remediation specialist.

### 4. Additional End User Costs And Responsibilities

#### Terms and conditions for replacing the Product that is being evaluated for limited warranty.

1. After evaluation by a certified HVAC/R technician and the Product is found to be un-repairable in the field, contact WhisperKOOL Customer Service to arrange for replacement under the warranty guidelines. When a claim for warranty is submitted for a condenser skid, the End User must purchase a new condenser skid from WhisperKOOL at retail price. Upon installation of the new condenser skid by a certified HVAC/R Technician, the HVAC/R Technician must complete the Installation Checklist and End User must submit the Installation Checklist to WhisperKOOL Customer Service for approval. The original condenser skid must be returned within 21 days to WhisperKOOL for failure analysis. If the Installation Checklist is approved and the failure is evaluated as defective and not installation error or other reason, the End User will be refunded for the cost of the replacement skid.
2. If the Product failure is evaluated and it is determined that it is an installation error or other reason, all costs, including shipping will be the responsibility of the End User.

The following items are not covered under any warranty and are the sole responsibility of the End User:

- A. End Users should satisfy themselves that the Product they are purchasing is suitable for their particular needs and requirements, and thus no responsibility will be placed with WhisperKOOL for the End User's decisions in this regard.
- B. End Users must assure that the product is installed by a certified HVAC/R technician. Failure to do so will result in Voiding the Limited Warranty.
- C. It is the End User's responsibility to secure safe haven/storage for ANY AND ALL items that are being kept and stored in the End User's wine cellar, including any Product. WhisperKOOL takes no responsibility for the safety and preservation of the aforementioned items in the event that the environment becomes unsuitable to maintain a proper storage environment.
- D. End User is responsible for initial installation costs, including, but not limited to, labor costs and the cost of any additional parts necessary to complete the installation.
- E. End User is responsible for all costs incurred for the installation and/or removal of the Product, or any part thereof, unless such cost has been agreed by WhisperKOOL to be a warranty repair prior to the work being performed.

### 5. Sales and Use Tax

WhisperKOOL only collects California sales tax for orders shipped within the State of California; WhisperKOOL does not collect sales tax for orders shipped to other states. However, the Purchaser and the End User may be liable to the taxing authority in their state for sales tax and/or use tax on the Product. The Purchaser and the End User should each check with their state's taxing authority for sales and use tax regulations.

### 6. Customer Service and Troubleshooting

WhisperKOOL's customer service department is available to answer any questions or inquiries for End Users regarding a WhisperKOOL Product, as well as to assist in performing basic troubleshooting, Monday through Friday, from 6:00 a.m. to 4:00 p.m. PST, at telephone number 1-800-343-9463. WhisperKOOL reserves the right to have a certified, WhisperKOOL-approved, HVAC/R technician go on site and inspect the product if the initial trouble shooting warrants further investigation. WhisperKOOL Corporation is located at 1738 East Alpine Avenue, Stockton, California 95205.

## 7. Request for Product Evaluation and Repair Under Warranty

**SPLIT SYSTEM FIELD SERVICE WARRANTY POLICY:** This Policy is to clarify what falls under Warranty Service and what becomes the responsibility of the Owner. WhisperKOOL (“manufacturer”) strives to provide our customers with a superior Product and we back our Product with a Two Year Limited Warranty. Please review the WhisperKOOL Product Terms and Conditions including Product Limited Warranty and Product Installation Requirements to ensure you have a complete understanding of our Policy and coverage of your Split System.

**ARBITRATION:** Any disputes arising out of or in connection with the installation and warranty of the Split System shall be referred to and finally resolved by a WhisperKOOL approved Independent Certified HVAC/R Technician. The evaluation of the Technician on all issues or matters of identifying the responsible party (WhisperKOOL or Installing Technician) shall be determined in a written report. This report will be made available to all concerned parties. If discovered under warranty, WhisperKOOL will assume the financial responsibility under their warranty guidelines. If the report finds the Owner’s Installer as the responsible party, WhisperKOOL will provide all documentation to the customer to substantiate the findings. This will include the Invoice from the Independent Certified HVAC/R Technician and the written report of the findings. The Owner will become responsible for payment directly to WhisperKOOL for all charges incurred for repairs (labor, parts and shipping costs) on the Split System.

## 8. Miscellaneous Terms and Conditions

- A. Return Policy. All return inquiries must be made within thirty (30) calendar days of the original purchase of a Product and are subject to a twenty five percent (25%) restocking fee. Shipping costs are not refundable and the Purchaser is responsible for all return shipping costs (including customs fees and duties, if applicable).
- B. Security Interest. WhisperKOOL retains a security interest in each Product until payment in full.
- C. Construction and Severability. Every provision of these Terms and Conditions shall be construed, to the extent possible, so as to be valid and enforceable. If any provision of these Terms and Conditions is held by a court of competent jurisdiction to be invalid, illegal or otherwise unenforceable, such provision will, to the extent so held, be deemed severed from the contract of sale between Purchaser and WhisperKOOL, and all of the other non-severed provisions will remain in full force and effect.
- D. Governing Law/Choice of Forum. The laws of the State of California (without regard for conflicts of law) shall govern the construction and enforcement of the these Terms and Conditions of Sale (Sections 1 through 9 inclusive, including Product Limited Warranty And Product Installation Requirements), and further these Terms and Conditions of Sale shall be interpreted as through drafted jointly by WhisperKOOL and Purchaser. Any dispute will be resolved by the courts in and for the County of San Joaquin, State of California, and all parties, WhisperKOOL, Purchaser and End User, hereby irrevocably submit to the personal jurisdiction of such courts for that purpose. No waiver by WhisperKOOL of any breach or default of the contract of sale (including these Terms and Conditions of Sale) concerning a Product will be deemed to be a waiver of any preceding or subsequent breach or default.
- E. Correction of Errors and Inaccuracies. These Terms and Conditions may contain typographical errors or other errors or inaccuracies. WhisperKOOL reserves the right to correct any errors, inaccuracies or omissions, and to change or update these Terms and Conditions, at any time without prior notice.

## 9. Questions, Additional Information And Technical Assistance

- A. Questions. If you have any questions regarding these Terms and Conditions or wish to obtain additional information, contact us via phone at 1-800-343-9463 or please send a letter via U.S. Mail to:

Customer Service  
WhisperKOOL Corporation  
1738 E Alpine Ave  
Stockton, CA 95205  
  
E-mail: [support@whisperkool.com](mailto:support@whisperkool.com)  
Web: [www.whisperkool.com](http://www.whisperkool.com)

- B. Technical Assistance. WhisperKOOL Customer Service is available Monday through Friday from 6:00 a.m. to 4:00 p.m. PST. The Customer Service representative will be able to assist you with your questions and warranty information more effectively if you provide them with the following:
  - 1. The model and serial number of your WhisperKOOL UNIT.
  - 2. The location of the system and installation details, such as ventilation, construction of your wine cellar, and room size.



# NOTES

Model \_\_\_\_\_ Serial Number \_\_\_\_\_

Installed by \_\_\_\_\_ Date \_\_\_\_\_

*Whisper***KOOL**<sup>™</sup>

WhisperKOOL  
1738 E. Alpine Ave  
Stockton, CA 95205  
1-800-343-9463  
[www.whisperkool.com](http://www.whisperkool.com)